

The background features a large, light gray graphic consisting of several overlapping circles and arcs, resembling a stylized atomic model or a network diagram. The word "Intermec" is written in a bold, italicized, sans-serif font, with a small black triangle pointing to the left above the letter 'I'.

Intermec



User's Manual

**EasyCoder[®] 4420
and 4440 Bar Code
Label Printer**

Intermec Technologies Corporation
6001 36th Avenue West
Everett, WA 98203
U.S.A.

U.S. service and technical support: 1-800-755-5505
U.S. media supplies ordering information: 1-800-227-9947

Canadian service and technical support: 1-800-668-7043
Canadian media supplies ordering information: 1-800-268-6936

Outside U.S.A. and Canada: Contact your local Intermec service supplier.

The information contained herein is proprietary and is provided solely for the purpose of allowing customers to operate and/or service Intermec manufactured equipment and is not to be released, reproduced, or used for any other purpose without written permission of Intermec.

Information and specifications in this manual are subject to change without notice.

© 2003 by Intermec Technologies Corporation
All Rights Reserved

The word Intermec, the Intermec logo, INCA (under license), MobileLAN, JANUS, IRL, Trakker Antares, EZBuilder, TE 2000, Data Collection Browser, dcBrowser, Universal Access Point, UAP, Duratherm, EasyCoder, Precision Print, PrintSet, Virtual Wedge, and CrossBar are either trademarks or registered trademarks of Intermec.

Novell is a registered trademark of Novell, Inc.

Kimdura is a registered trademark of Kimberly Clark.

Kapton is a registered trademark of Dupont.

Speedo, Dutch, and Swiss are registered trademarks of Bitstream Inc.

The name Windows is a registered trademark of Microsoft Corporation.

IBM is a registered trademark of International Business Machines Corporation.

Throughout this manual, trademarked names may be used. Rather than put a trademark (™ or ®) symbol in every occurrence of a trademarked name, we state that we are using the names only in an editorial fashion, and to the benefit of the trademark owner, with no intention of infringement.

There are U.S. and foreign patents pending.

Manual Change Record

This page records the changes to this manual. The manual was originally released as version 001.

Version	Date	Description of Change
002	10/2001	Updated the user's guide to support latest hardware version of the 4420 and 4440 printers.
003	3/2003	Updated the user's manual to include the EasyLAN 10i2 adapter accessory and the EasyLAN wireless option.

Contents

Before You Begin.....	ix
Warranty Information	ix
Safety Summary.....	ix
Warnings, Cautions, and Notes	x
About This Manual	x
Other Intermec Manuals	xi

1 Getting Started..... 1

Learning About the Printer	2
Understanding the Front Panel.....	3
Using the Front Panel LEDs.....	3
Using the Front Panel LEDs for Troubleshooting	4
Using the Feed/Pause Button.....	5
Preparing the Printer for Installation	5
Connecting the Printer to a Power Source	6
Opening the Printer.....	7
Loading Media Into the Printer	7
Loading Roll Media.....	8
Loading Fanfold Media	9
Loading Thermal Transfer Ribbon	11
Printing the Hardware Configuration Test Label.....	14
Setting the Media Sensitivity Number	15
Setting the MSN for Intermec Media and Ribbon.....	16
Setting the MSN for Other Media and Ribbon	17

2 Installing the Printer..... 21

Connecting the Printer to Your System	22
Connecting the Printer to a PC	22
Connecting the Printer to a PC Serial Port	23
Connecting the Printer to a PC Parallel Port	23
Connecting the Printer to a Network.....	23
Connecting the Printer to an AS/400.....	24
Connecting the Printer to a Mainframe	24
Cabling in Noisy Electrical Environments	24
Configuring the Serial Port for Communications	25

Communicating With the Printer.....	27
Using the PrintSet Software.....	27
Using Third-Party Software.....	27
Using Intermec Printer Language (IPL) Commands.....	27
Using PrintSet to Test Communications	28
3 Maintaining the Printer.....	29
Inspecting the Printer	30
Maintenance Schedule	30
Tools for Cleaning the Printer	31
Cleaning the Printhead	32
Cleaning the Printer Covers.....	34
Cleaning the Rollers and the Tear Bar	34
Cleaning the Media Guides and Media Path.....	36
Cleaning the Label Sensors	37
4 Troubleshooting the Printer	39
Troubleshooting Checklist.....	40
Printer Operation Problems.....	40
Print Quality Problems.....	42
Communication Problems.....	44
Preventing Data Loss	44
5 Optimizing Printer Performance	47
Optimizing and Maintaining Print Quality	48
Correcting Uneven Print Quality	48
Adjusting the Print Darkness	49
Fine-Tuning the Top of Form Position	51
Adjusting the Label Gap Sensor.....	54
Adjusting the Label Mark Sensor.....	56
Using the Printer Memory Efficiently.....	57
How Is the Printer Storage Memory Used?.....	57
Making the Most of the Memory.....	57
Increasing Throughput	58
What Is an Image Band?.....	58
How the Image Bands Command Works	58
Optimizing Print Speed and Image Band Setting.....	59

6	Using Test and Service Mode	61
	Using Test and Service Mode Procedures	62
	Printing Test Labels.....	64
	Using Data Line Print Mode	64
	Performing Selective Transfer	64
	Using Memory Reset	65
	Setting Configuration Commands in Test and Service Mode	66
	Setting the Number of Dot Increments	67
	Adjusting the Label Rest Point.....	68
	Setting Emulation Mode	69
	Using Forms Adjust.....	71
	X Forms Adjust	72
	Y Forms Adjust.....	72
A	Specifications	75
	4420 and 4440 Printer Specifications	76
	Dimensions (no options installed)	76
	Electrical Requirements	76
	Environment	76
	Character Sets.....	76
	Fonts and Graphics.....	76
	Media Specifications.....	77
	Memory.....	77
	Printhead.....	78
	Printing Method.....	78
	Printing Speed	78
	Ribbon Specifications	78
	Factory Default Settings.....	78
	Printer Options	79
	Communications Interfaces	79
	EasyLAN 10i Interface.....	79
	EasyLAN 10i2 Adapter.....	80
	EasyLAN Wireless Option.....	80
	Coax Interface	80
	Twinax Interface.....	80
	Finishers	80
	Cutter.....	80
	Self-Strip/Full Roll Batch Takeup.....	80
	Kanji/Katakana.....	81
	Memory Expansion	81

Bar Code Symbolologies Supported.....81
 2D Symbolologies82
 2D Stacked Symbolologies82
 2D Matrix Symbolologies.....83

B Character Sets 85

International Character Sets.....86
 Advanced Character Table.....86
 Emulation Mode Character Table86
 IBM Translation Character Table.....87
 Code Page 850 Character Table.....88

Extended Character Sets89

C Communications Reference 93

Communications Protocols94
 Intermec Standard Protocol.....94
 XON/XOFF Protocol (Software and Hardware Flow Control)95
 Polling Mode D.....96
 Multi-Drop Protocol96
 Hardware Protocol96
 User-Defined Protocol.....97
 Host Requirements.....98
 Communications Boundaries.....98

Communications Interfaces98
 RS-232 Serial Interface99
 RS-422 Serial Interface99
 RS-485 Serial Interface99

Printer Serial Port.....100

G Glossary 103

I Index..... 111

Before You Begin

This section introduces you to standard warranty provisions, safety precautions, warnings and cautions, document formatting conventions, and sources of additional product information. A documentation roadmap is also provided to guide you in finding information in this manual.

Warranty Information

To receive a copy of the standard warranty provision for this product, contact your local Intermec support services organization. In the U.S.A call 1-800-755-5505, and in Canada call 1-800-668-7043. If you live outside of the U.S.A or Canada, you can find your local Intermec support services organization on the Intermec web site at www.intermec.com.

Safety Summary

Your safety is extremely important. Read and follow all warnings and cautions in this book before handling and operating Intermec equipment. You can be seriously injured, and equipment and data can be damaged if you do not follow the safety warnings and cautions.

Do not repair or adjust alone

Do not repair or adjust energized equipment alone under any circumstances. Someone capable of providing first aid must always be present for your safety.

First aid

Always obtain first aid or medical attention immediately after an injury. Never neglect an injury, no matter how slight it seems.

Resuscitation

Begin resuscitation immediately if someone is injured and stops breathing. Any delay could result in death. To work on or near high voltage, you should be familiar with approved industrial first aid methods.

Energized equipment

Never work on energized equipment unless authorized by a responsible authority. Energized electrical equipment is dangerous. Electrical shock from energized equipment can cause death. If you must perform authorized emergency work on energized equipment, be sure that you comply strictly with approved safety regulations.

Warnings, Cautions, and Notes

The warnings, cautions, and notes in this manual use the following format.



A warning alerts you of an operating procedure, practice, condition, or statement that must be strictly observed to avoid death or serious injury to the persons working on the equipment.

Avertissement: Un avertissement vous avertit d'une procédure de fonctionnement, d'une méthode, d'un état ou d'un rapport qui doit être strictement respecté pour éviter l'occurrence de mort ou de blessures graves aux personnes manipulant l'équipement.



A caution alerts you to an operating procedure, practice, condition, or statement that must be strictly observed to prevent equipment damage or destruction, or corruption or loss of data.

Attention: Une précaution vous avertit d'une procédure de fonctionnement, d'une méthode, d'un état ou d'un rapport qui doit être strictement respecté pour empêcher l'endommagement ou la destruction de l'équipement, ou l'altération ou la perte de données.



Note: Notes are statements that either provide extra information about a topic or contain special instructions for handling a particular condition or set of circumstances.

About This Manual

Analysts and programmers should use this manual to learn how to operate, program, and connect the printer to a network or system. The first part of this manual tells you how to install, operate, maintain, and troubleshoot your printer. The last part of the manual covers advanced features of the 4420 and 4440 printers. A basic understanding of programming and data communications is necessary.

The following special terms and conventions occur throughout the manual. Refer to the glossary for a complete list of terms.

Terminology

Term	Description
Printer	Printer refers to the 4420 and the 4440 bar code label printer.
4420 or 4440	4420 or 4440 refers to the specific model 4420 or 4440 bar code label printer.
media	Media is the label stock (including thermal transfer ribbon) on which the printer prints labels.
host	Host refers to a personal computer or other computer that communicates with the printer.

The following conventions are used throughout this manual for operating procedures and descriptions of the printer:

- Feed/Pause refers to the Feed/Pause button on the printer front panel.
- Downloaded commands appear in the order that you enter them into the printer with the following conventions:

Format Conventions

Convention	Description
< >	Angle brackets < > enclose mnemonic representations of ASCII control characters. For example, <ETX> represents the ASCII “End of Text” control character.
<i>data</i>	Italic text represents variable data, which you must replace with a real value. For example, <i>n</i> signifies a variable for which you must designate a constant value.
[<i>data</i>]	Italic text within brackets represents optional data.
Ctrl	Bold text represents a key on your keypad. For example, Ctrl represents the Ctrl key.
Ctrl-Z	When two keys are joined with a dash, press them simultaneously. For example, if you see the command Ctrl-Z , press the two keys at the same time.
E3 ; F3	Type all characters that appear in the Courier font by pressing an individual key on the keypad.

Other Intermec Manuals

You may need additional information when working with the 4420 or 4440 in a data collection system. Please visit the Intermec web site at www.intermec.com to download many of our current manuals in PDF format. To order printed versions of the Intermec manuals, contact your local Intermec representative or distributor.

Before You Begin



1 Getting Started

This chapter introduces the 4420 and 4440 printer and explains how to get your new printer up and running. This chapter covers these topics:

- Learning about the printer
- Understanding the front panel
- Preparing the printer for installation
- Setting the media sensitivity number

Learning About the Printer

Features of the 4420 and 4440 printer include:

- High throughput
- IEEE 1284 parallel port
- 18,000 inch ribbon capacity
- Simple user interface
- Moveable label gap sensor
- Up to 10 inches per second (ips) print speed with selected media
- Thermal transfer and direct thermal printing support

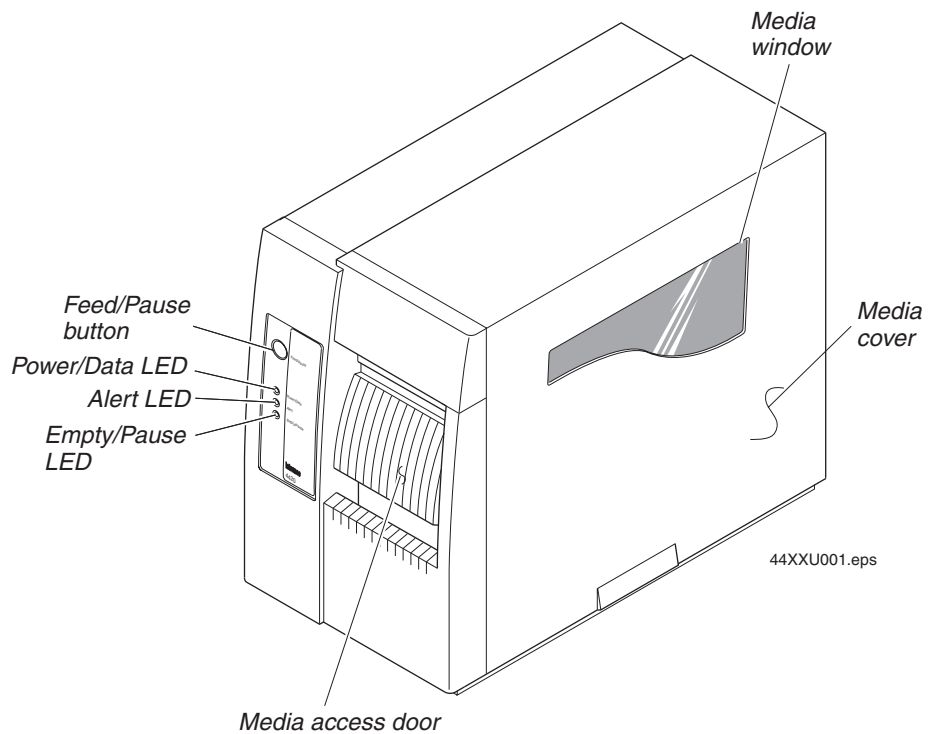

4420 and 4440 front view: This illustration shows the 4420 and 4440 features on the front of the printers.

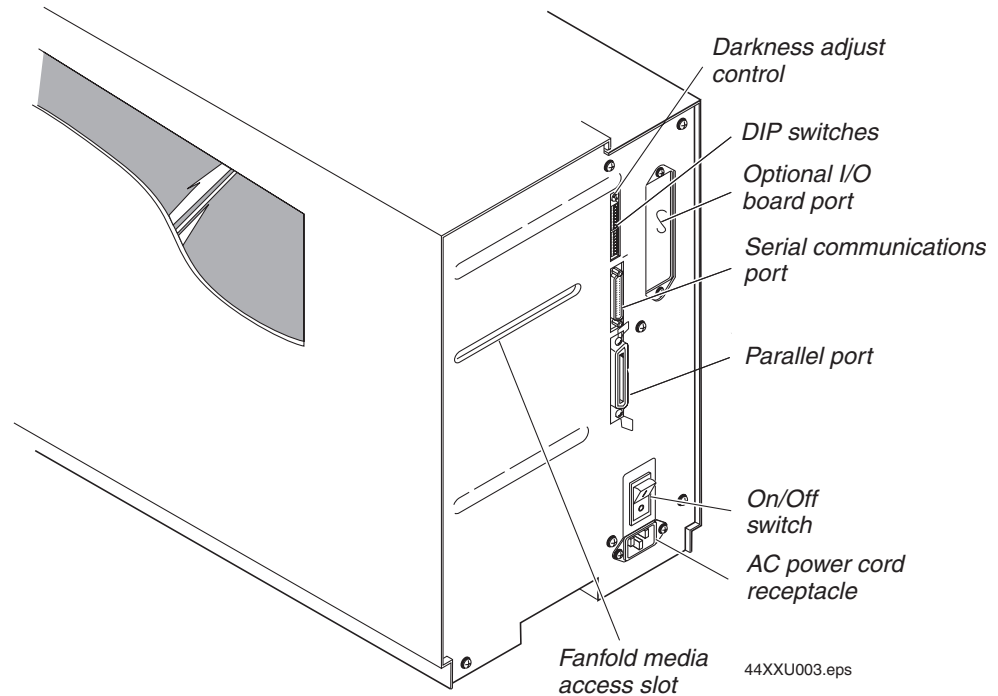

4420 and 4440 back view: This illustration shows the 4420 and 4440 features on the back of the printers.

Several options are available for use with the 4420 and 4440 printer. See Appendix A, “Specifications,” for a complete description of each option.

Understanding the Front Panel

This section explains the function of the front panel LEDs and the Feed/Pause button.

Using the Front Panel LEDs

You use the front panel LEDs to monitor the status of the printer.

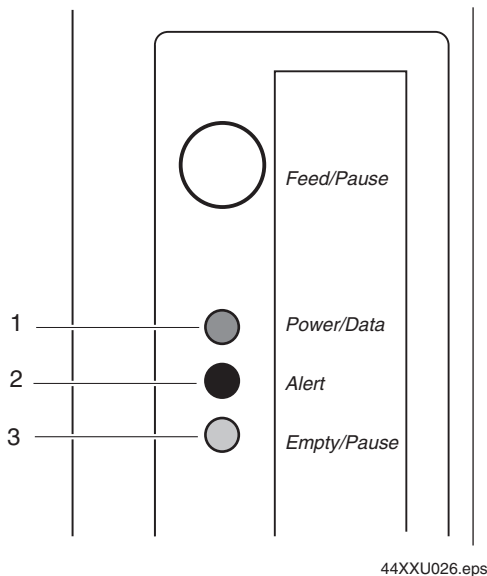

Front panel LEDs: This illustration shows the LEDs that are on the front panel of the printers. For help understanding these LEDs, see the next LED Descriptions table.

LED Descriptions

Number	LED	State	Indication
1	Power/Data	Off	Power off
		On	Power on
		Flashing	Receiving data
2	Alert	Off	Printing or idle
		Flashing	Over-temperature
		On	System fault
3	Empty/Pause	Off	Printing or idle
		Flashing	Paused
		On	Media fault

Using the Front Panel LEDs for Troubleshooting

You can use the front panel LEDs to troubleshoot the printer.

LED States for Problems

Problem	LED State
Over-Temperature	If the printer overheats, the Alert LED flashes and the printer stops. Do not try to troubleshoot or adjust the printer—just allow it enough time to cool down and it will resume operation on its own. You should only encounter this problem after extended print jobs.
Media or System Faults	If the Empty/Pause or the Alert LED remains on, the printer is experiencing a media or system fault. See Chapter 4, “Troubleshooting the Printer,” for help in correcting the problem.

Using the Feed/Pause Button

The Feed/Pause button, located on the front panel of the 4420 or 4440 printer, performs several functions depending on the mode of the printer.

Feed/Pause Button Functions

Printer Mode	You Want To	What to Do
Idle	Feed out one label or a minimum specified amount of media.	Press and release the Feed/Pause button.
	Continuously feed media.	Press and hold the Feed/Pause button. When you release the button, the media stops feeding.
	Take the printer offline.	Press the Feed/Pause button twice. Press the button again to bring the printer online.
Printing	Pause the printer.	Press and release the Feed/Pause button. Press and release the button again to resume printing.
	Cancel the current print job.	Press and hold the Feed/Pause button until the printer stops printing.
Turned on for the first time	Print the hardware configuration test label.	Press and hold the Feed/Pause button. See “Printing the Hardware Configuration Test Label” later in this chapter.

Preparing the Printer for Installation

Before connecting the printer to your data collection system, you need to

- 1 connect the printer to a power source.
- 2 open the printer.
- 3 load media.
- 4 load ribbon.
- 5 print a hardware configuration test label.

These steps are described in the next sections.

Connecting the Printer to a Power Source

The back of the printer contains the AC power cord receptacle, the serial communications port, the parallel communications port, the accessory port, the darkness adjust, the On/Off switch, and two banks of DIP switches.

To connect the printer to a power source

- 1 Turn off the printer.
- 2 Make sure the DIP switches on the back of the printer are set to their factory default settings.

Top Bank Turn on switch 1. Turn off switches 2 through 8.

Bottom Bank Turn off switches 1 through 8.

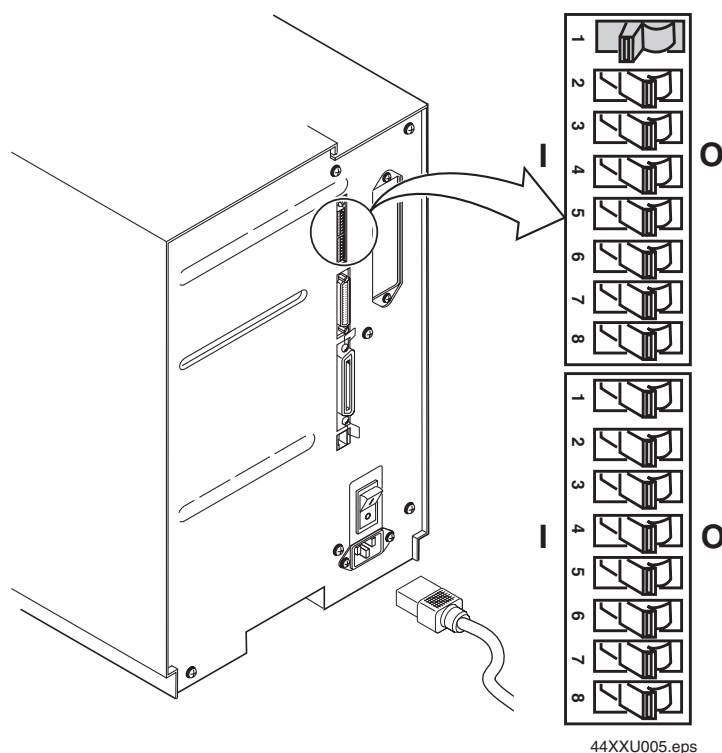

- 3 Plug the AC power cord into the receptacle at the rear of the printer.
- 4 Plug the other end of the power cord into a grounded wall outlet or surge protector.
- 5 Turn the printer on.

When you turn on the printer, the green light emitting diode (LED) lights and the platen roller advances. The yellow LED lights until you load media.

Opening the Printer

You need to open the printer when you load media or perform maintenance procedures.

To open the printer

- 1 Place the fingers of your right hand under the embossed section of the media cover (the media cover release) and pull the bottom of the media cover away from the base of the printer.
- 2 Grasp the front of the media cover with your left hand and lift the front of the media cover upward to release it from the printer frame.
- 3 Lift the media cover away from the top of the printer.

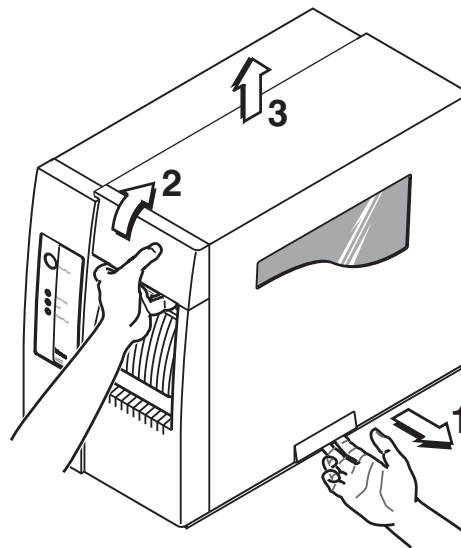

44XXU006.eps

Loading Media Into the Printer

The printer can print on rolls of or fanfold thermal transfer or direct thermal media. The default setting for the printer is direct thermal mode. However, the sample media that shipped with the printer is thermal transfer. If you are using thermal transfer media, you need to load thermal transfer ribbon and change the media type setting. For help loading the ribbon, see “Loading Thermal Transfer Ribbon” later in this chapter. To change the media type setting, see “Configuring the Serial Port for Communications” in Chapter 2.



Note: You should find a small label with a three-digit sensitivity number printed on it attached to the roll of media or a 15 digit number stamped on the side of the media roll. Save this information. You will need it to set the correct media sensitivity number. For help, see “Setting the Media Sensitivity Number” later in this chapter.

Loading Roll Media

- 1 Raise the printhead by rotating the head lift lever clockwise until the printhead disengages.
- 2 Turn the supply roll retainer counterclockwise to release it and then slide it to the outer end of the supply roll post. Turn it clockwise to lock it in place.



Note: If you are replacing the empty media roll with a new roll of the same width, you do not need to adjust the edge guide or the supply roll retainer.

- 3 Place the media roll on the supply roll post and position it firmly against the printer.
- 4 Insert the media support between the roll of media and the supply roll retainer before securing it.
- 5 Turn the supply roll retainer counterclockwise and slide it lightly up against the media support. Turn the supply roll retainer clockwise to secure.
- 6 Loosen the edge guide and slide it all the way to the outer edge of the lower media guide. Tighten it in place.
- 7 Pull down on the lower media guide to allow easy access to the media path.
- 8 Unroll several inches of media and insert it between the media guide plates as shown below. Make sure the label passes between the upper and lower media guides and out the front of the printer.

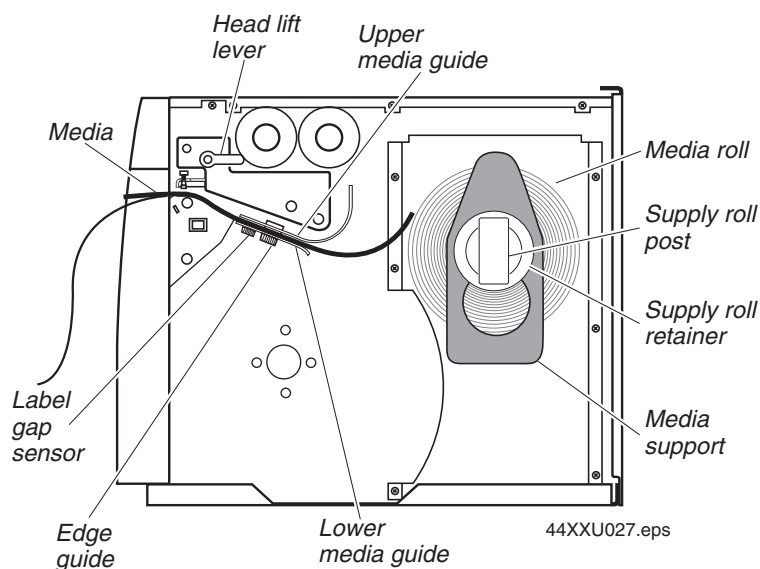

- 9 Release the lower media guide and adjust the edge guide (by loosening it and sliding it) to position the media firmly against the inside wall of the printer.
- 10 Adjust the label gap sensor position if necessary. For help, see “Adjusting the Label Gap Sensor” in Chapter 5.
- 11 If you are using thermal transfer media, you need to load ribbon. Follow the instructions for “Loading Thermal Transfer Ribbon” later in this chapter before you finish performing this procedure.
- 12 Lower the printhead by rotating the head lift lever counterclockwise until it locks.
- 13 If you are loading continuous media or mark label stock, use PrintSet, your third-party software, or the printer command set to tell the printer what kind of media you are using.
- 14 Press the Feed/Pause button to advance several inches of media through the printer and out the label opening in the front cover. The yellow Empty/Pause LED goes out.



Note: If the yellow Empty/Pause LED does not go out, reload the media and try again.



Note: In the future, you may want to refer to the label located on the inside of the media cover for directions on loading media.

Loading Fanfold Media

In fanfold printing, you place a stack of fanfold media at the rear of the printer and feed it into the printer through a slot in the rear cover.

To load fanfold media

- 1 Open the printer.
- 2 Rotate the head lift lever clockwise to release the printhead.
- 3 Turn the supply roll retainer counterclockwise and slide it to the outer end of the supply roll post. See the next illustration.

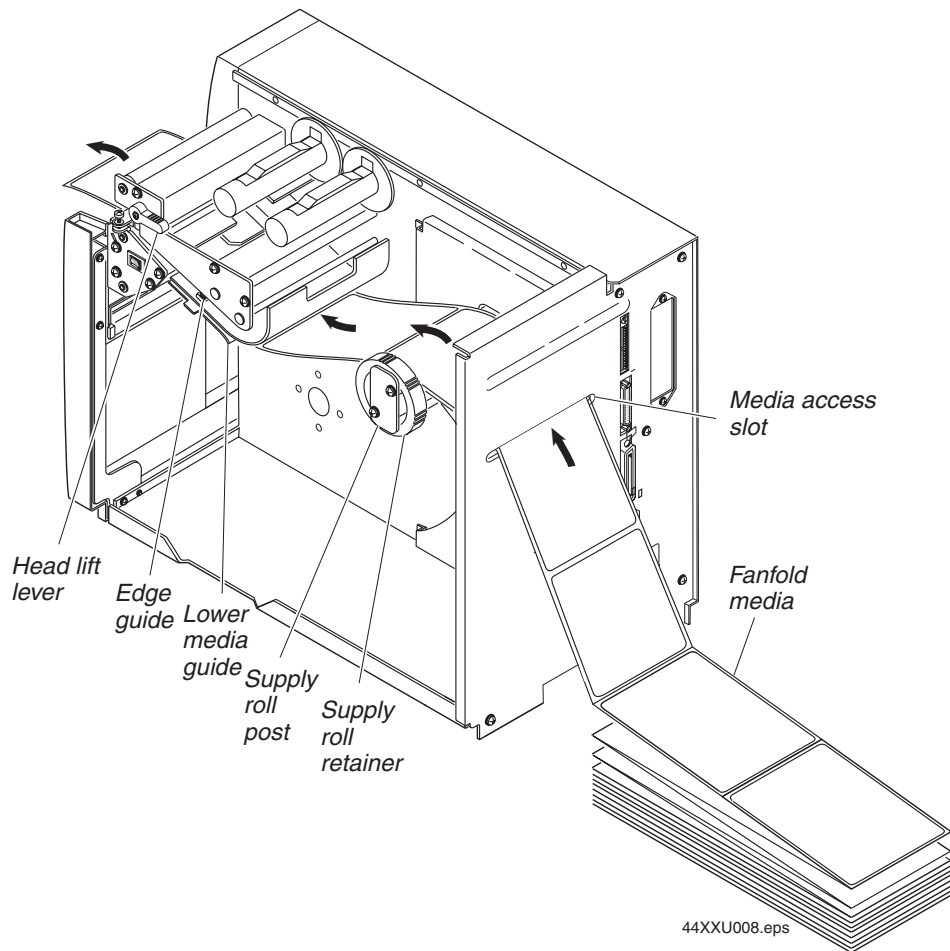

- 4 Place the fanfold media slightly lower than the slot in the printer back cover. Align the fanfold media with the label path through the printer. Insert media through the slot at the rear of the printer and thread it over the supply roll post.
- 5 Unscrew the edge guide and slide it to the outer edge of the lower media guide. Screw it in place.
- 6 Pull down on the lower media guide to allow easy access to the media path.
- 7 Insert the fanfold media through the printer mechanism as shown in the previous illustration. The fanfold media passes over the supply roll post and out the front opening of the printer.
- 8 Release the lower media guide and adjust the edge guide to position the media firmly against the inside wall of the printer.
- 9 Slide the supply roll retainer up to the edge of the fanfold media and turn the supply roll retainer clockwise until it locks firmly in place. This action secures the media against the inside wall of the printer.
- 10 Rotate the head lift lever counterclockwise until it locks to engage the printhead.

- 11 Replace the media cover.
- 12 Press the Feed/Pause button to advance one label through the printer. The yellow Empty/Pause LED goes out.



Note: If the yellow Empty/Pause LED does not go out, reload the media and try again.



Note: In the future, you may want to refer to the label located on the inside of the media cover for directions on loading media.

Loading Thermal Transfer Ribbon

If you plan to print in thermal transfer mode, you must install thermal transfer ribbon (TTR) on the ribbon supply hub after you install the thermal transfer media. You also must use thermal transfer media and change the media type setting. For help loading the media, see “Loading Media Into the Printer” earlier in this chapter. To change the media type setting, see “Configuring the Serial Port for Communications” in Chapter 2.



Note: Save the packaging that your ribbon came in. Attached to the ribbon packaging is a small label with a three-digit sensitivity number printed on it. You need this information to set the correct media sensitivity number. For help, see “Setting the Media Sensitivity Number” later in this chapter.

The core of your thermal transfer ribbon is either made of cardboard or plastic. You need to use the correct core-locking brackets for your ribbon core. The printer ships from the factory with the cardboard core-locking brackets already attached.



Note: If you do not use the correct core-locking brackets, you may experience printing problems or possible damage to the printer.

To change the cardboard core-locking brackets to plastic core-locking brackets

- 1 Pull up on the middle of the cardboard core-locking bracket (P/N 065375), while pushing down on one end with your index finger, until the end of the bracket is free of the ribbon hub.
- 2 Remove the other end of the bracket from the ribbon hub.
- 3 Slide one end of the plastic core-locking bracket (P/N 066792) into a bracket slot on the ribbon hub.

- 4 Lift up on the middle of the bracket and use your index finger to slide the other end of the bracket into the remaining bracket slot on the ribbon hub.

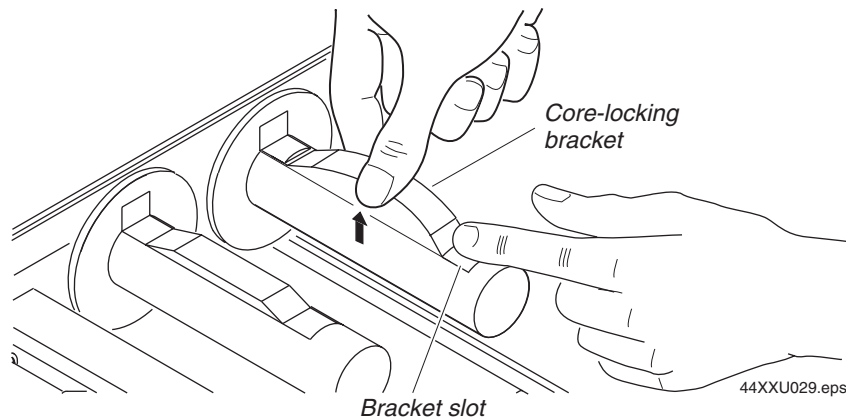

To load thermal transfer ribbon

- 1 Make sure you have raised the printhead. If not, turn the head lift lever clockwise until it releases the printhead.
- 2 Place the empty ribbon core that came with the printer onto the ribbon rewind hub.
- 3 Detach the leader from the new thermal transfer ribbon roll and unwind the end of the ribbon approximately 20.32 cm (8 in). The edge of the ribbon has a leader (with an adhesive strip on the leader edge) for guiding the ribbon through the printhead mechanism.
- 4 Slide the roll of thermal transfer ribbon onto the ribbon supply hub with the ribbon roll winding clockwise.
- 5 Route the ribbon leader through the printer mechanism as shown in the following illustration.
- 6 Attach the leader from the new thermal transfer ribbon roll to the empty ribbon core using the adhesive strip on the leader edge.



- Note:** Make sure the ribbon runs above the upper media guide. The shiny side of the ribbon must come in contact with the printhead.
- 7 Wind the ribbon rewind hub clockwise until the ribbon runs smoothly through the printhead mechanism and the leader moves past the printhead.

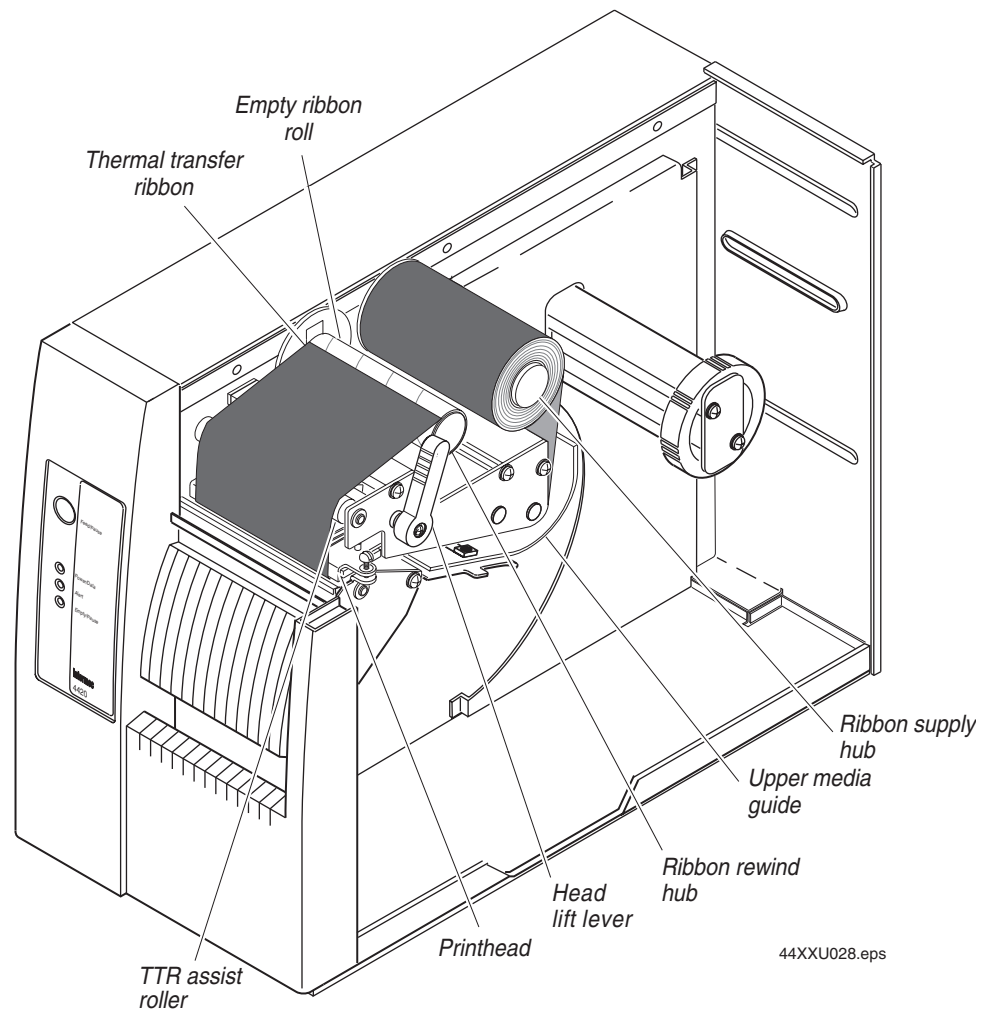

- 8 Engage the printhead by rotating the head lift lever counterclockwise until it locks.
- 9 Enable thermal transfer printing by setting DIP switch 8 on the bottom bank of switches to the on position. Refer to “Configuring the Serial Port for Communications” in Chapter 2 for DIP switch settings.
- 10 Press the Feed/Pause button to advance the ribbon through the printer. The printer is now ready to print the hardware configuration test label.



Note: When replacing the thermal transfer ribbon roll in the future, use the empty ribbon supply core as the new rewinder core.

Printing the Hardware Configuration Test Label

You can print the hardware configuration test label to test the printer and make sure it is operating correctly. The hardware configuration test label lists the printer's configuration and provides information on the status of the printer hardware. Use this label for reference when connecting the printer to your system.

To print the hardware configuration test label

- 1 Turn off the printer.
- 2 Press and hold the Feed/Pause button while you turn the printer on. The Alert and Empty/Pause LEDs blink during the printer self-test.
- 3 Release the Feed/Pause button when the media starts moving. The printer feeds out one or two blank labels and then prints the hardware configuration test label.
- 4 Turn the printer power off and then on again.

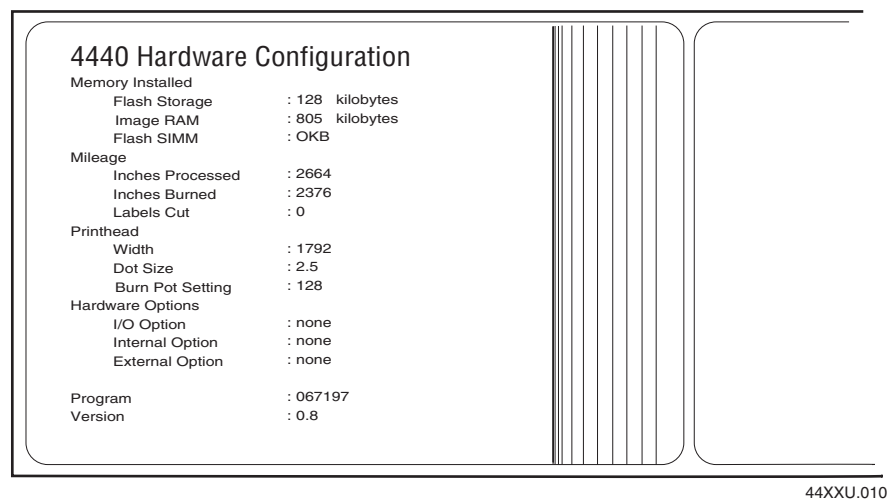

Note: The hardware configuration label defines the above parameters. Individual values vary between printers.

If you are unable to print a hardware configuration test label, see “Printer Operation Problems” in Chapter 4.

Setting the Media Sensitivity Number

The media sensitivity number (MSN) is important, because you use it to optimize print quality and print speed. The three-digit MSN specifies the amount of heat required by the printhead to image a label. The amount of heat that each roll of media or ribbon requires is unique due to different chemistries and manufacturing processes.

Intermec has developed heating schedules (the amount of heat required to image a label) to produce the highest possible print quality for Intermec media and ribbon combinations on Intermec printers. Look for the three-digit MSN on

- the side of the media roll. Use the last three digits (140 in the example) of the 15 digit number stamped on the roll for the MSN.
- a small label attached to the roll of media.
- a small label attached to the plastic bag of your ribbon roll.

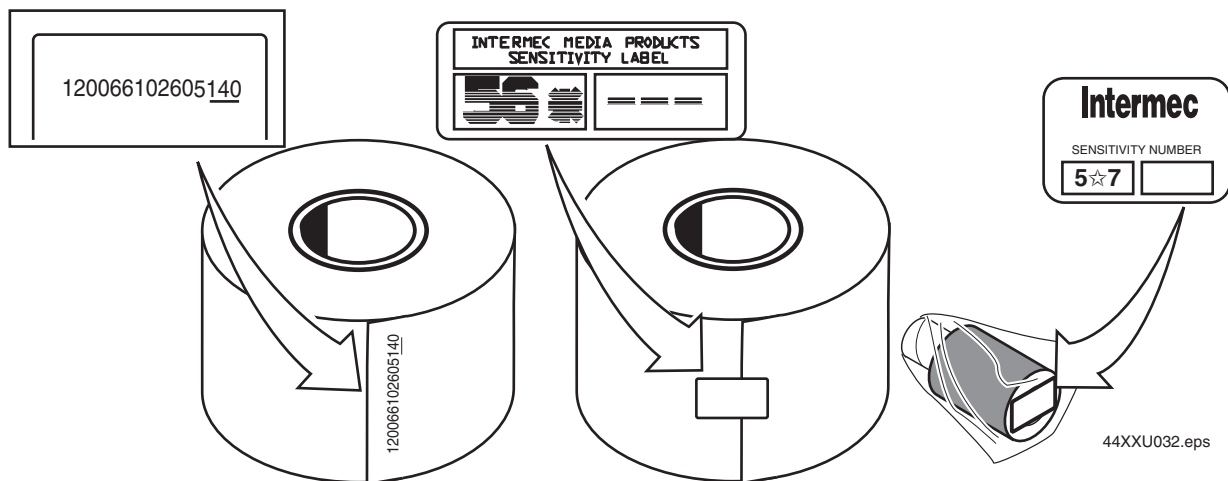

MSN: This illustration shows you where to find the MSN. Note that some ribbon rolls have the MSN printed inside of the core.

Use this three-digit number to optimize print quality and print speed on the printer. You can achieve the best print quality on the 4420 or 4440 printer by using only Intermec ribbon and media products. This table lists the default MSN:

Default MSNs

Media Type	Default
Direct thermal media (2 to 5 ips)	470
Direct thermal media (6 to 8 ips)	720
Thermal transfer media (2 to 10 ips)	567

Use the PrintSet software, your third-party software, or the Intermec Printer Language (IPL) command set to change the MSN. If you do not know the sensitivity numbers for your media or ribbon, use the PrintSet Print Quality Assistant to help you choose the correct MSN. If you want to see the current sensitivity setting of your printer, print out a software configuration label.

To print a software configuration label

- 1 Turn off the printer.
- 2 Press and hold the Feed/Pause button while turning the printer on. The printer prints out a hardware configuration label.
- 3 Set the DIP switches to print out the software test label.
Top Bank Turn off switches 1 through 6 and 8. Turn on switch 7.
Bottom Bank Turn off switches 1 through 8.
- 4 Hold the Feed/Pause button down for 1 second. The printer prints out the software configuration label.
- 5 Return the DIP switches to their original settings.
- 6 Turn the printer off and then on again.

Setting the MSN for Intermec Media and Ribbon

The sensitivity number on each roll of thermal transfer media or ribbon has an asterisk (*) in place of one of the digits. To optimize the sensitivity number for thermal transfer media, you combine the digits as in this example.

Example: Setting the Sensitivity Number

Media or Ribbon	Sensitivity Number	Description
Thermal transfer media	56*	The asterisk reserves the third digit to identify the ribbon's sensitivity number.
Thermal transfer ribbon	5*7	The asterisk reserves the second digit to identify the media's sensitivity number.
	567	Optimized media sensitivity number

To set the sensitivity number for direct thermal media, use the three-digit sensitivity number located on the roll of media or listed in the Direct Thermal Media Sensitivity Settings table later in this chapter.

To set the MSN with PrintSet

- 1 Start PrintSet on your PC.
- 2 Click the Media Type button.



The Media Type dialog box appears.

- 3 On the Print Quality Setup tab, enter your three-digit number in the Media Sensitivity Number field.

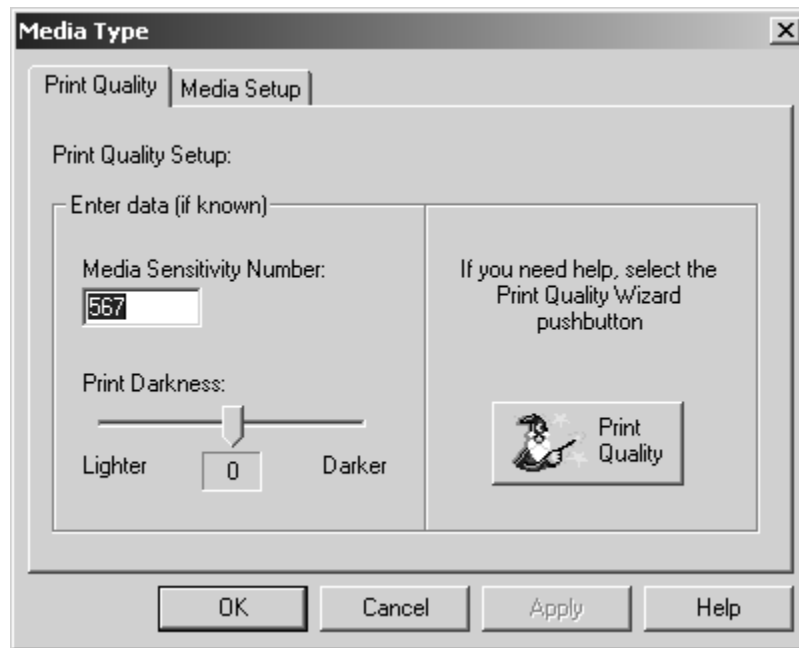

- 4 Click OK.
- 5 Download your change to the printer by pressing the button to send command updates to the attached printer.

**Setting the MSN for Other Media and Ribbon**

If you are not using Intermec media and ribbon, or you misplaced your packaging with the three-digit sensitivity number label on it, you can set the approximate sensitivity rating. The first column of the Direct Thermal and Thermal Transfer Media Sensitivity Settings tables list the approximate sensitivity settings. To achieve acceptable print quality, enter the three-digit MSN (for example, 800).

If you are unsure of how to set the media sensitivity rating, start with the highest setting, which provides the lowest energy (800 for thermal transfer

and 700 for direct thermal), and work your way down until you achieve the best print quality.



Note: The hardware configuration label defines the above parameters. Individual values vary between printers.

Use the maximum recommended print speed only as a guideline. Optimize your individual print speed based on your media and the format that you want to print. If you exceed the maximum recommended print speed, you may notice reduced print quality.

Direct Thermal Media Sensitivity Settings

Approximate Sensitivity Ratings	Sensitivity Setting	Direct Thermal Media	Maximum Recommended Print Speed
700 Series High Sensitivity	720	Duratherm Lightning Plus 2	8 ips
400 Series Medium Sensitivity	480	Duratherm Lightning IR Tag	5 ips
	470	Duratherm Lightning-1	5 ips
	460	European IR	5 ips
	450	Duratherm IR Lightning-1	5 ips
	440	European Thermal	5 ips
	420	Duratherm Lightning-2	5 ips
100 Series Low Sensitivity	180	Duratherm II-1	3 ips
	170	European Tag	3 ips
	160	Duratherm II Tag	3 ips
	140	European Top	3 ips
	130	Duratherm II-2	3 ips

Thermal Transfer Media and Ribbon Sensitivity Settings

Approximate Sensitivity Ratings	Sensitivity Setting	Direct Thermal Media	Maximum Recommended Print Speed
800 Series High Sensitivity (Paper)	864	European Uncoated/Standard	8 ips
	854	Duratrán TTR Paper Labels/Standard-1	6 ips
	834	Duratrán TTR Paper Tags/Standard-1	6 ips

Thermal Transfer Media and Ribbon Sensitivity Settings (continued)

Approximate Sensitivity Ratings	Sensitivity Setting	Direct Thermal Media	Maximum Recommended Print Speed
600 Series Medium Sensitivity (Plastic)	687	Duratran TTR Polyester or Valeron/Premium-7	6 ips
	677	Duratran Syntran/Premium-7	6 ips
	647	Duratran Tyvek/Premium-7	4 ips
	643	European Tyvek/Premium	4 ips
	633	European Polyethelene/Premium	8 ips
	627	Duratran Kimdura/Premium-7	10 ips
	623	European Kimdura/Premium	6 ips
500 Series Medium Sensitivity (Paper)	567	Duratran II-1/Premium-7	10 ips
	565	European Premium Paper/Premium	7 ips
	563	Duratran VG/Standard	4 ips
	533	European Tag/Premium	6 ips
	527	Duratran II Tag-7 mil/Premium-7	6 ips
	513	European Coated/Premium	6 ips
300 Series Low Sensitivity (Plastic)	369	Super Premium Polyester/Super Premium-3	5 ips
	366	Super Premium Polyester/Super Premium-7	5 ips
200 Series Low Sensitivity (Kapton)	238	Gloss Polyimide (Kapton)/Gloss Super Premium	3 ips
	236	Gloss Polyimide (Kapton)/Super Premium-7	3 ips
	226	Matte Polyimide (Kapton)/Super Premium-7	3 ips
	222	Matte Polyimide (Kapton)/Matte Super Premium	3 ips



2 Installing the Printer

This chapter explains how to connect the printer to your PC or network and configure the serial port for communications. This chapter covers these topics:

- Connecting the printer to your system
- Configuring the serial port for communications
- Communicating with the printer
- Using PrintSet to test communications

Connecting the Printer to Your System

You can connect the printer to a PC, a local area network, an AS/400 (or other midrange), or a mainframe. This section explains how to connect the printer to any of these systems.

You can use any of these three ports on the rear of the printer:

- Serial communications port
- Parallel port
- Optional I/O board port (if you have an interface card installed)

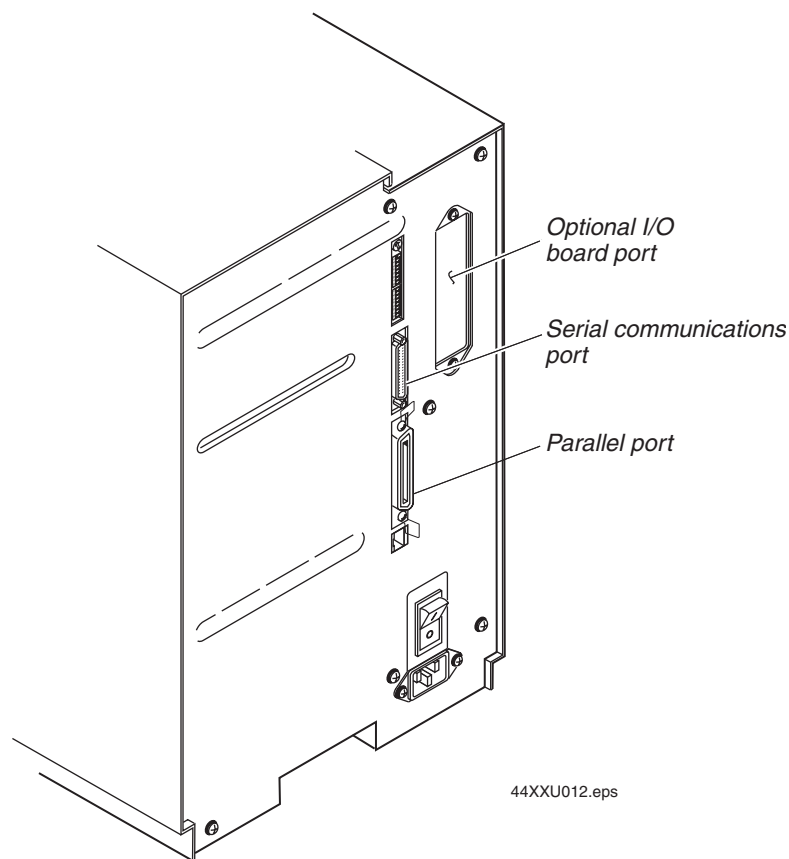

Printer ports: This illustration shows you where to connect your system to the printer.

Connecting the Printer to a PC

You can connect the printer to either a serial (COM) port or a parallel port on your PC. You must provide the correct cables for connecting the printer. Contact your Intermec representative for ordering assistance if you do not have the appropriate cables.

Connecting the Printer to a PC Serial Port

To connect the 4420 or 4440 to your PC serial port, you need a shielded EIA RS-232, RS-422, or RS-485 electrical interface with a 25-pin D-style subminiature connector. You can purchase the Intermec serial 9F-25M null modem cable (P/N 048693) or purchase a compatible cable from your local computer store.

Currently, Intermec does not offer a cable for the RS-422 interface. However, you will find a schematic in Appendix C that you can use to purchase or make your own cable. Also see Appendix C for the RS-232, RS-422, and RS-485 serial port assignments.

To connect the printer to a PC serial port

- 1 Turn off the printer.
- 2 Plug the 25-pin connector into the serial communications port on the rear of the printer.
- 3 Plug the other end of the cable into a serial port on the PC.
- 4 If necessary, change the PC serial port configuration to match the printer. See “Configuring the Serial Port for Communications” later in this chapter for more information.

Connecting the Printer to a PC Parallel Port

If you are using a parallel port to communicate with the printer, you need a parallel cable to run between the printer and the PC. You can purchase the Intermec IEEE 1284 parallel cable (P/N 590124) or purchase a compatible cable from your local computer store.

To connect the printer to a PC parallel port

- 1 Turn off the printer.
- 2 Plug the parallel interface connector into the parallel communications port on the rear of the printer.
- 3 Plug the other end of the cable into a parallel port on the PC.

Connecting the Printer to a Network

You can connect the printer to Novell NetWare networks, Ethernet networks, token ring networks, or other TCP/IP networks. To connect the printer to a network, you must have an interface card (for example, EasyLAN 10i2) installed. Ethernet, coax, and twinax cards are field or factory installed.

If you need to change the printer’s communications parameters, follow the procedures in “Configuring the Serial Port for Communications” later in this chapter.

Connecting the Printer to an AS/400

To connect the printer directly to an AS/400 or midrange computer, you need

- a twinax adapter card (P/N 067879).
- a twinax cable equivalent to IBM part number 7362267 or 7362062. The maximum cable length for the twinax interface is 1,525 meters (5,000 feet).

If you did not order the twinax card to be installed at the factory, contact your local Intermec representative to have one installed in the optional I/O board port of the printer.

For help on cabling and communications, see the manual that comes with the twinax adapter card.



Note: If you are using a midrange computer other than the AS/400, refer to your system documentation for information on cabling and setting up communications.

Connecting the Printer to a Mainframe

To connect the printer directly to an IBM mainframe, you need

- a coax adapter card (P/N 067880).
- a coax cable equivalent to IBM part number 2577672 or 1833108.

If you did not order the coax card to be installed at the factory, contact your local Intermec representative to have one installed in the optional I/O board port of the printer.

The maximum cable length allowed is 1,500 meters (4,920 feet). See the IBM specification *Installation and Assembly of Coaxial Cable and Accessories*, part number GA27-2805-4, for further information.

For help on cabling and communications, see the manual that comes with the coax adapter card.

Cabling in Noisy Electrical Environments

The items listed below create noisy electrical environments that can disrupt data communications between your host computer and the printer:

- Large power transformers
- Large electrical motors
- Arc welders
- Motor controllers
- Switch gears

If any of these items are near the printer, you may want to try any of the following suggestions to reduce the effects of electrical noise. If you need help eliminating noise, ask your Intermec representative for assistance.

- Always use shielded cable. Connect the cable and shield to the metal backshells on the cable connectors and fasten the connectors to the serial ports using screws.
- Install ferrite cable clamps.
- Connect the printer chassis ground to the building ground. You will find the chassis ground on the ground pin of the printer power cord.

Configuring the Serial Port for Communications

You need to configure the serial port of the printer to match the configuration of your PC or network controlling device. If the printer's default settings do not match, use the DIP switch settings table to configure the serial port.



Note: You need to configure the printer serial port for 8 data bits if you want to print code pages or 8-bit ASCII character sets. Also, use XON/XOFF protocol for Ready/Busy buffer control.

To configure the printer serial port

- 1 Use the following DIP Switch Settings Descriptions table to locate the DIP switches you use to configure the serial port.
- 2 Use a small straight-slot screwdriver to set the appropriate DIP switches.
For example, if you want to change the media type to thermal transfer, set DIP switch 8 on the bottom bank of switches to the on position.
- 3 Turn the printer power off and then on for the configuration changes to take effect.



Note: Make sure you set all Multi-Drop switches to off if you are not using a Multi-Drop network.

DIP Switch Settings Descriptions

Parameter	Description
Baud rate	The rate, in bits per second, at which the host exchanges data with the printer.
Parity	Adds one bit (1 or 0) to the character to make the sum of bits always odd or even.
Data bits	The number of bits (7 or 8) that represent the ASCII characters.
Batch takeup	Enables or disables the optional batch takeup/self-strip motor.
Multi-Drop address	Unique address for each device connected with Multi-Drop protocol.

DIP Switch Settings Descriptions (continued)

Parameter	Description
Protocol	The transmission standards for communication between the printer and each connecting device.
Media type	Enables the printer to work with either direct thermal or thermal transfer media.

Top Bank Switch Number

O = OFF
1 = ON

Baud Rate Selection							
19,200	0	0	0				
9,600*	1	0	0				
4,800	0	1	0				
2,400	1	1	0				
1,200	0	0	1				
38,400	1	0	1				
57,600	0	1	1				
115,200	1	1	1				
Parity Selection							
Even*				0	0		
Odd				1	0		
None				0	1		
None				1	1		
Number of Data Bits							
7 Bit*						0	
8 Bit							1
Reserved							0
BatchTakeup							
Disabled *							0
Enabled							1

Default settings are noted with an *

Bottom Bank Switch Number

O = OFF
1 = ON

Multi-Drop Address Selection							
*A	0	0	0	0	0		
B	1	0	0	0	0		
C	0	1	0	0	0		
D	1	1	0	0	0		
E	0	0	1	0	0		
F	1	0	1	0	0		
G	0	1	1	0	0		
H	1	1	1	0	0		
I	0	0	0	1	0		
J	1	0	0	1	0		
K	0	1	0	1	0		
L	1	1	0	1	0		
M	0	0	1	1	0		
N	1	0	1	1	0		
O	0	1	1	1	0		
P	1	1	1	1	0		
Q	0	0	0	0	1		
R	1	0	0	0	1		
S	0	1	0	0	1		
T	1	1	0	0	1		
U	0	0	1	0	1		
V	1	0	1	0	1		
W	0	1	1	0	1		
X	1	1	1	0	1		
Y	0	0	0	1	1		
Z	1	0	0	1	1		
0	0	1	0	1	1		
1	1	1	0	1	1		
2	0	0	1	1	1		
3	1	0	1	1	1		
4	0	1	1	1	1		
5	1	1	1	1	1		
Protocol Selection							
XON/XOFF Industry Standard*						0	0
XON/XOFF Intermec Standard						0	1
Intermec auto Discriminate						1	0
Intermec Multi-Drop						1	1
Media Type							
Direct Thermal*							0
Thermal Transfer							1

Default settings are noted with an *

44XXU020.eps

DIP switch settings: These charts illustrate the settings for the DIP switches on the top and bottom banks. For a description of each setting, see the DIP Switch Settings Descriptions table earlier in this chapter.

Communicating With the Printer

Now that your printer is connected to your system, you are ready to print labels by downloading data from the host to the printer. *Downloading* is the universal term used to describe the transfer of information from the host to any connected peripheral device, such as the printer. When you transfer data from your printer to the host, you are performing a process called *uploading*.

You can use several methods to download information in your data collection system. This section describes three different ways to communicate with the printer:

- 1 Using the PrintSet software
- 2 Using third-party software
- 3 Using Intermec Printer Language (IPL) commands

Using the PrintSet Software

You can install the PrintSet application software from the Printer Companion CD that shipped with the printer. Use PrintSet to easily configure your printer from your PC. You can also use PrintSet to

- download graphics and fonts (including TrueType).
- print test labels.
- modify and download configuration files.

Refer to the online help for information on using PrintSet.

Using Third-Party Software

You can use third-party software to set many of the printer parameters. You can configure the parameters that your software does not set by using the printer command set or the configuration DIP switches.

Use your third-party software to create label formats and convert graphics into a user-defined character (UDC) format that the printer can interpret. Refer to your third-party documentation and the *IPL Programming Reference Manual* (P/N 066396) for more information.

Using Intermec Printer Language (IPL) Commands

You can create labels by downloading formats (designs) and data with IPL commands. You can use the IPL commands to perform any function or activate any feature of the printer except for those features or functions that you set with the DIP switches.

For help using IPL commands, see the *IPL Programming Reference Manual*.

Using PrintSet to Test Communications

If you would like to test communications between your host and the printer, you can use PrintSet to download a test label.

To print the test label

- 1 Start PrintSet on your PC.
- 2 Click the Test Print button.



- 3 Select the Test Label option button.
- 4 Select either the Text or the Bar Code option button.

If you select to print text, you can choose a font in the Select Printer Font list box.

If you select to print a bar code, you can choose a symbology in the Select Symbologies list box.

- 5 Click the Print button. Your printer prints out a test label.

For example, if you chose to print a bar code with the Code 39 symbology, your printer prints out a label similar to this one:



44XXU033.eps



3 Maintaining the Printer

This chapter explains how to clean and maintain the printer. Even though the printers can withstand harsh environments, you must clean them on a regular basis to maximize performance. It is very important to perform the maintenance procedures if you expose the printer to dirt or debris. This chapter covers these topics:

- Inspecting the printer
- Maintenance schedule
- Cleaning the printhead
- Cleaning the printer covers
- Cleaning the rollers and tear bar
- Cleaning the media guides and media path
- Cleaning the label sensors

Inspecting the Printer

Inspect the printer and the rest of your data collection system equipment on a regular basis. Your inspection should include these tasks:

- Make sure you have properly grounded the printer.
- Inspect the work environment. Large electric motors, welders, and switching equipment can affect printer performance.
- Check the data collection network regularly for loose wires or poorly installed connections. Be sure to replace corroded wires.

Maintenance Schedule

Clean the printer regularly to maintain the quality of the labels and extend the life of the printer. This table contains suggestions for cleaning the printer. Use the following illustration to locate the parts you need to clean.

Printer Maintenance Schedule

Printer Component	Maintenance Period
Thermal printhead	Inspect after every roll of media. Clean after every roll of media (6,000 in or 152 m) or ribbon (18,000 in or 457 m). Clean more often if necessary.
Printer Cover (not shown)	Clean as necessary.
Drive roller and tear bar	Clean after every six rolls of media. If you are using hi-tack adhesive, you must clean after every roll of media. Clean more often in environments that are harsh or dusty.
Media path (not shown)	
Edge guide	
Upper media guide	
Lower media guide	
Thermal transfer ribbon (TTR) assist roller	
Label gap sensor (not shown)	
Label mark sensor (not shown)	

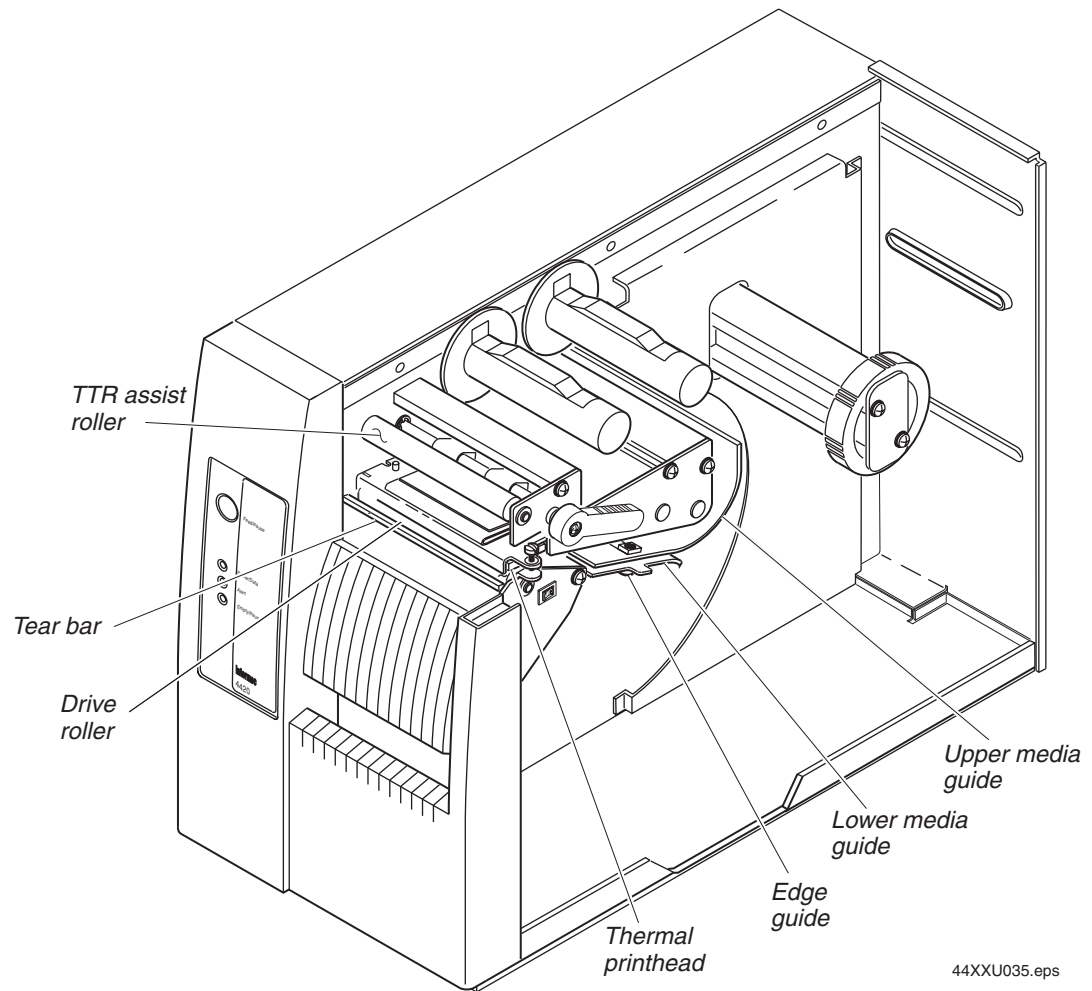

Printer parts: This illustration shows the printer parts that need to be cleaned. For a maintenance schedule of each part, see the Printer Maintenance Schedule table earlier in this chapter.

Tools for Cleaning the Printer

To clean the printer safely and effectively, use these items:

- Cleaning card (P/N 1-110501-00)
- Cotton swabs
- Isopropyl alcohol
- Clean lint-free cloth
- Soft bristle brush or vacuum cleaner
- Soapy water or mild detergent

The following procedures explain how to access the printer parts and clean them without causing any harm to the printer or yourself.



Switch off the printer power and remove the power cord before cleaning any part of the printer.

Avertissement: Mettez l'imprimante hors tension et débranchez le câble d'alimentation avant de nettoyer une partie de l'imprimante.

Cleaning the Printhead

In order for the printhead to provide good print quality, it must maintain close contact with the media. Therefore, cleaning media debris from the printhead is very important. Clean after every roll of media (152 m or 6,000 in) or ribbon (457 m or 18,000 in). Clean more often if necessary. There are two ways to clean the printhead:

- Use the cleaning card.
- Use a cotton swab and isopropyl alcohol.



Do not use sharp objects such as knives or screwdrivers to scrape the printhead clean. Cleaning with sharp objects will damage the printhead.

Attention: N'utilisez pas d'objets pointus tels que couteaux ou tournevis pour nettoyer la tête d'imprimante. Nettoyer avec des objets pointus endommagera la tête d'imprimante.

To clean the printhead using the cleaning card

- 1 Turn off the printer and remove the power cord.
- 2 Remove the media cover.
- 3 Disengage the printhead by rotating the head lift lever clockwise until the printhead releases. This raises the printhead so that you can clean it.
- 4 Remove the media and ribbon.
- 5 Open the pouch and remove the cleaning card.

- 6 Insert the cleaning card into the printer following the media path.

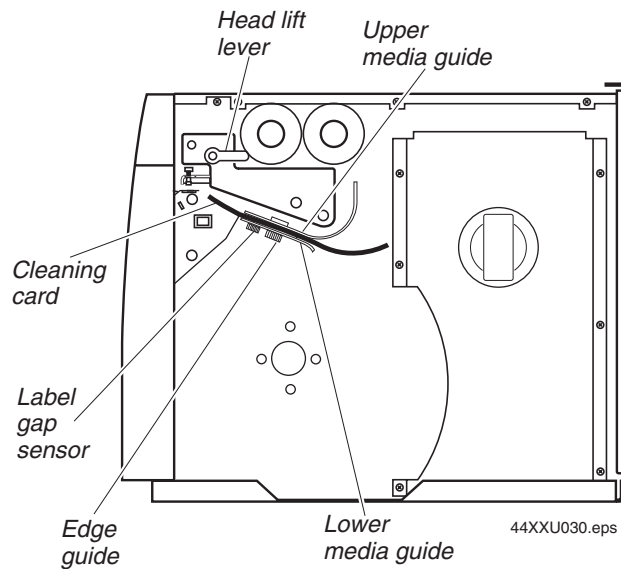

- 7 Engage the printhead by rotating the head lift lever counterclockwise until it locks in place.
- 8 Use one hand to hold the printer and use the other hand to pull the cleaning card forward until you have pulled the entire card through the media path.
- 9 Repeat Steps 6 through 8.
- 10 Dispose of the cleaning card properly.
- 11 If you are finished cleaning, replace the media cover.

To clean the printhead using a cotton swab and isopropyl alcohol

- 1 Turn off the printer and remove the power cord.
- 2 Remove the media cover.
- 3 Disengage the printhead by rotating the head lift lever clockwise until the printhead releases. This raises the printhead so that you can clean it.
- 4 Remove the media and ribbon if necessary.

- 5 Use a cotton swab moistened with alcohol to remove any dirt, adhesive, or debris from the print surface on the bottom of the printhead.

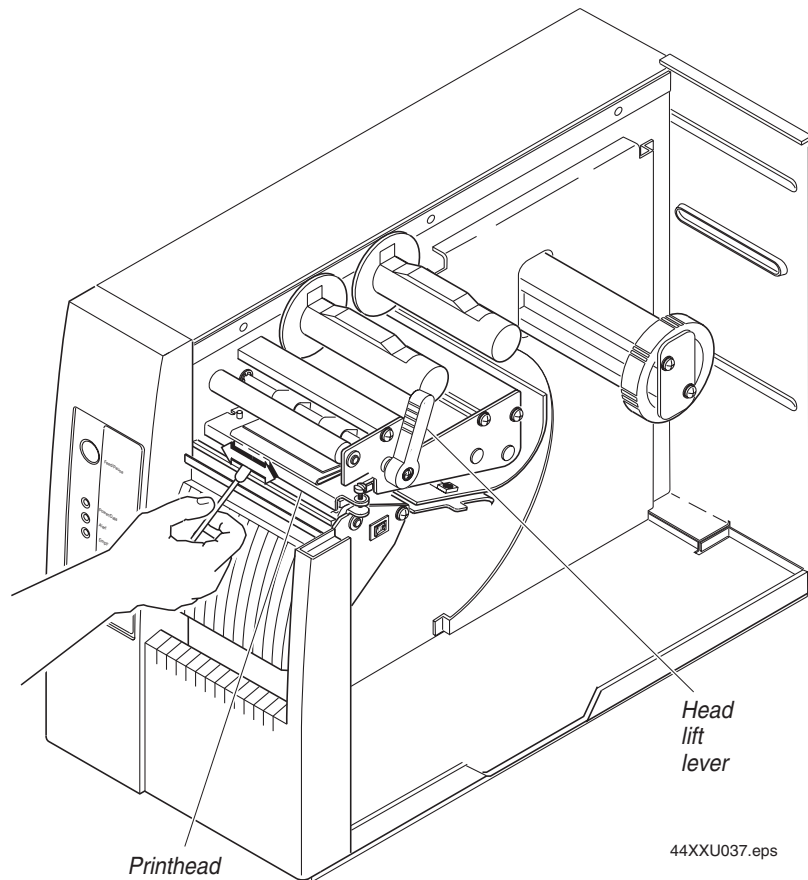

- 6 Wait 5 to 10 seconds for the print surface to dry. Replace the media and ribbon.
- 7 Engage the printhead by rotating the head lift lever counterclockwise until it locks in place.
- 8 If you are finished cleaning, replace the media cover.

Cleaning the Printer Covers

Clean the printer covers with a general purpose cleaner (soapy water or mild detergent). Do not use abrasive cleansers or solvents. Be sure to clean the transparent panel on the media cover so that the media supply inside the printer is visible when you close the cover.

Cleaning the Rollers and the Tear Bar

Cleaning the rollers and the tear bar preserves print quality by ensuring close contact between the media and the printhead.

To clean the rollers and tear bar

- 1 Turn off the printer and remove the power cord.
- 2 Remove the media cover.
- 3 Rotate the head lift lever clockwise to release the printhead.
- 4 Remove media and ribbon (if necessary).
- 5 Clean the rollers by using a cloth moistened with isopropyl alcohol. Move the cloth over the rollers in a side-to-side motion as shown. Make sure to rotate the rollers so that you can clean all areas.



Note: Rotate the TTR assist roller toward you to clean the entire drive roller surface.

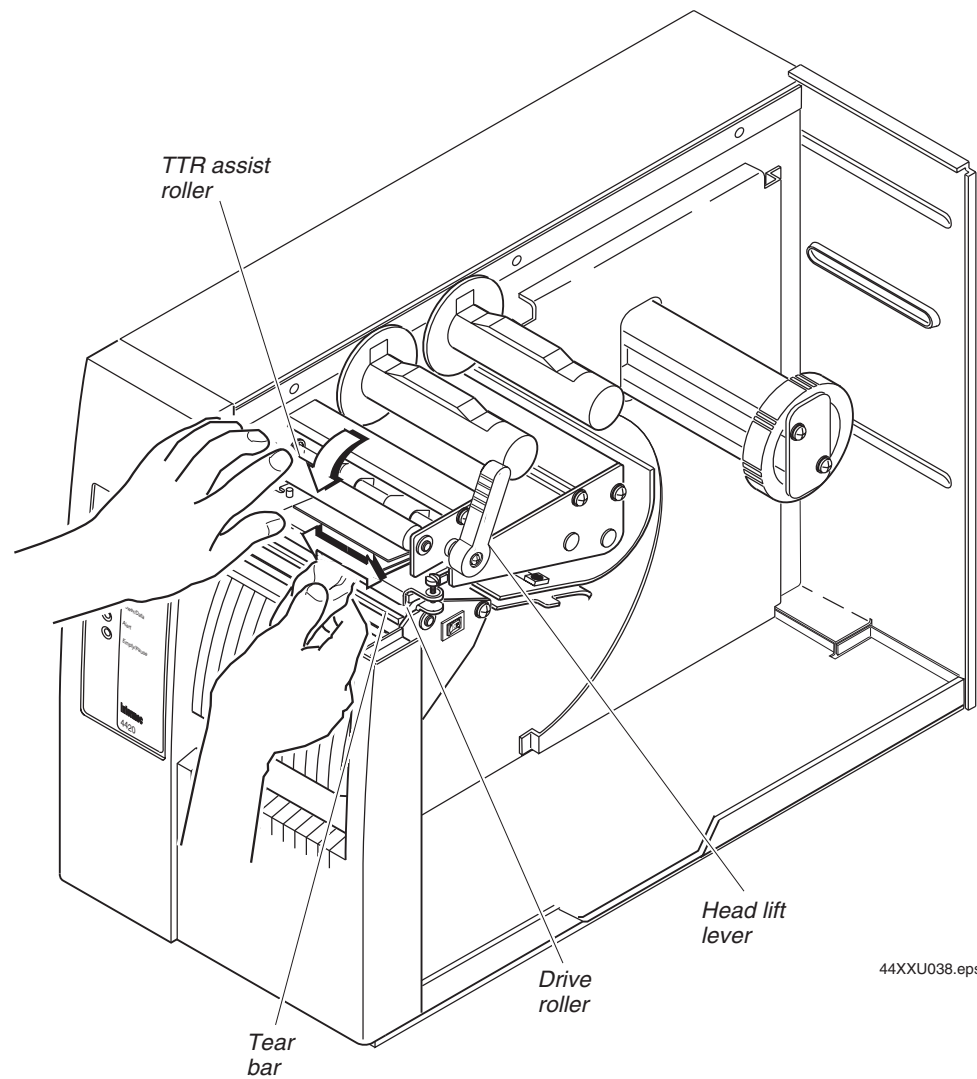

44XXU038.eps

- 6 Clean both sides of the tear bar with a cloth dampened with isopropyl alcohol. Remove all traces of dust, paper, and adhesive.
- 7 Replace the media and ribbon.
- 8 Engage the printhead by turning the head lift lever counterclockwise until the printhead locks.
- 9 If you are finished cleaning, replace the media cover.

Cleaning the Media Guides and Media Path

You should clean the media guides and media path regularly to keep debris off the media surface and printhead where irregularities can spoil print quality or damage the printhead. Cleaning the guides also prevents the media from skewing or improperly tracking as it travels through the media path, which can result in smeared images and print off the side of the label. Always clean the media guides immediately after a label jam in the printer.

To clean the media guides and media path

- 1 Turn off the printer and remove the power cord.
- 2 Remove the media cover.
- 3 Remove the media and ribbon (if necessary).
- 4 Pull down on the lower media guide to open up the media path.

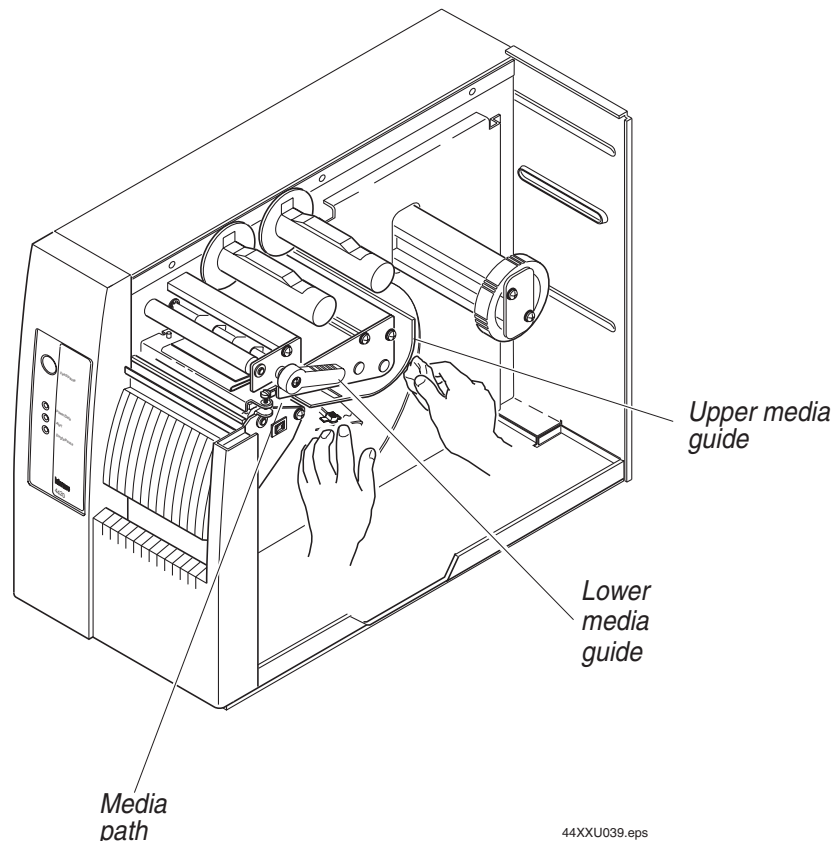

- 5 Clean the lower media guide by using a lint-free cloth moistened with isopropyl alcohol as shown in the following figure.



Note: The lower media guide is spring loaded. You must hold it open to clean.

- 6 Use the cloth moistened with isopropyl alcohol to clean the upper media guide. Be sure to remove all traces of debris.
- 7 Remove all traces of dust, paper, and adhesive from the media path with a soft bristle brush or vacuum.
- 8 Clean the flat surfaces of the media path (including the edge guide) with a lint-free cloth and isopropyl alcohol.
- 9 Release the lower media guide.
- 10 If you are finished cleaning, replace the media cover.

Cleaning the Label Sensors

Two label sensors on the printer require regular cleaning:

- Label mark
- Label gap

To clean the label sensors

- 1 Turn off the printer and remove the power cord.
- 2 Remove the media cover.
- 3 Disengage the printhead by rotating the head lift lever clockwise until the printhead releases.
- 4 Remove the media and ribbon (if necessary).

- 5 Clean the label mark sensor with a cotton swab moistened with isopropyl alcohol.

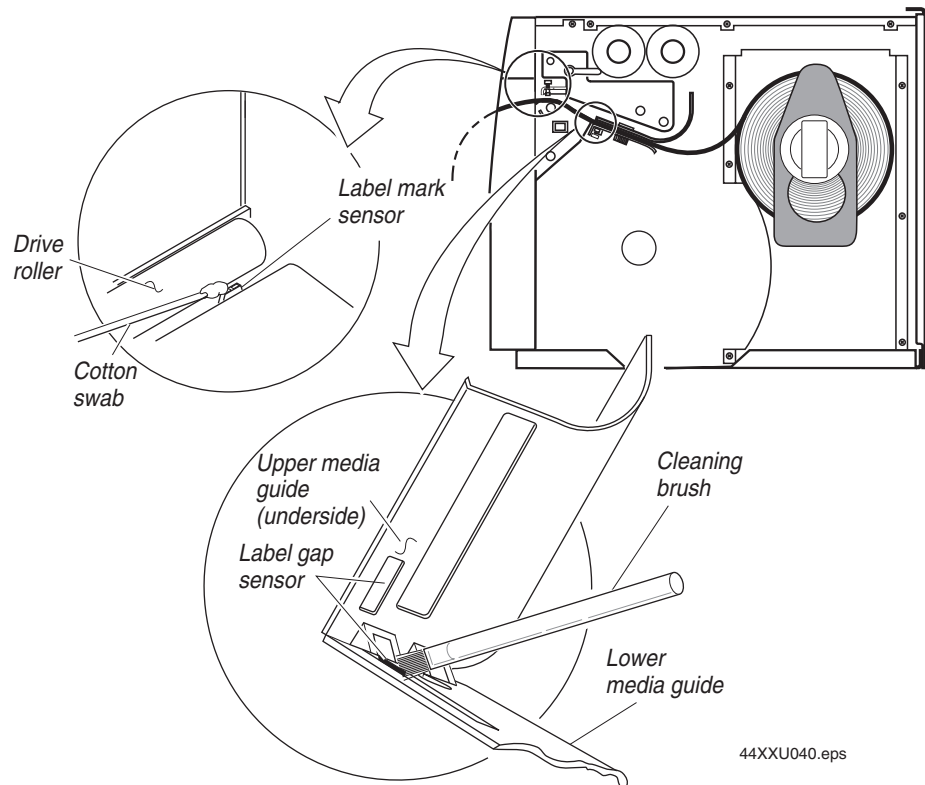

- 6 Pull down on the lower media guide to expose the label gap sensor. Using a cleaning brush or vacuum, remove all debris and dust from the label gap sensor.
- 7 Clean the upper and lower label gap sensor with a cotton swab and alcohol.
- 8 Replace the media and ribbon.
- 9 Engage the printhead by rotating the head lift lever counterclockwise until it locks in place.
- 10 If you are finished cleaning, replace the media cover.



4 Troubleshooting the Printer

This chapter provides some hints for troubleshooting error messages that the printer sends to the host and problems you may experience with the printer. This chapter covers these topics:

- Troubleshooting checklist
- Printer operation problems
- Printer quality problems
- Communication problems
- Preventing data loss

Troubleshooting Checklist

You may have printer operation, print quality, or printer communications problems at some time during the life of the printer. It is easy to fix most of the problems and consequently not delay operation of the printer for very long.

To troubleshoot the printer

- 1 First try cleaning the printer components and checking all of the connections. See Chapter 3, “Maintaining the Printer,” for details.
- 2 If cleaning the printer and checking the connections does not solve the problem, use the following tables to locate the symptom. Follow the solution in the table to fix the problem.

If you receive an error message, refer to the *IPL Programming Reference Manual* (P/N 066396) for a complete list of error messages and their solutions. An electronic copy of the *IPL Programming Reference Manual* is available on the Internet at www.intermec.com.

If the problem persists, contact an Intermec customer service representative. In the U.S.A. call 1-800-755-5505, and in Canada call 1-800-668-7043. If you are an international customer, contact your local Intermec representative.

Printer Operation Problems

If the printer is not operating correctly, try locating the problem in the table below:

Printer Operation Problems

Symptom	Possible Causes	Solution
No power or loss of power.	You have damaged or disconnected the AC power cable.	Make sure you have plugged the power cable into both the printer and an outlet or power strip. Replace the cable if damaged.
	Printer circuit breaker tripped.	Turn the printer off and back on again.
Labels stop feeding through the printer.	Printer is out of media.	Load new media. For help, see “Loading Media Into the Printer” in Chapter 1.
	You have loaded the label stock incorrectly.	Check the media path. For help, see “Loading Media Into the Printer” in Chapter 1.
	You have set the printer for continuous label stock.	Use PrintSet to check the configuration settings. If the settings are incorrect, use PrintSet to change the settings.
	Media is sticking to the paper path.	Clear any extraneous material from the paper path and clean it thoroughly. Refer to Chapter 3, “Maintaining the Printer.”

Printer Operation Problems (continued)

Symptom	Possible Causes	Solution
Printer slows down.	You have incorrectly set the image bands or print speed. Printer has aborted and reset the print speed and image bands.	Use PrintSet to change the image bands or print speed settings. Use PrintSet to change the image bands or print speed settings.
The Alert LED flashes and printing stops.	Printhead has overheated.	Leave printer alone until it has time to cool down. It will resume printing on its own.
Media fault.	The printhead is up. Sensor type set incorrectly. You have incorrectly loaded the media. Printer is out of media. One of the sensors is incorrectly located. Media type is set incorrectly.	Make sure the printhead is down. The head lift lever should be almost straight up and down (in the 1 o'clock position). Press the Feed/Pause button to resume printing. Configure the printer for the correct sensor, either label gap or label mark sensor. Use PrintSet to configure the correct sensor. Try reloading the media. For help, see "Loading Media Into the Printer" in Chapter 1. Load new media. For help, see "Loading Media Into the Printer" in Chapter 1. Adjust the label gap sensor or the label mark sensor to the correct location for the label stock you are using. For help, see "Adjusting the Label Gap Sensor" or "Adjusting the Label Mark Sensor" in Chapter 5. Make sure the DIP switch for media type is set correctly. For help, see "Configuring the Serial Port for Communications" in Chapter 2.
Test configuration label does not print.	You have incorrectly loaded the media. Media fault. You have configured the printer for self-strip media.	Try reloading the media. For help, see "Loading Media Into the Printer" in Chapter 1. See possible media fault causes and solutions above. Set the printer to the default configuration using the DIP switches. For help, see "Connecting the Printer to a Power Source" in Chapter 1.
Printer is not communicating, not printing, or not printing properly.	Corrupt or incorrect information in the printer memory.	Reset the memory to return the printer to its default configuration. For help, see "Using Memory Reset" in Chapter 6. After you reset the memory, power off the printer and return the DIP switches to the required setting. For help, see "Configuring the Serial Port for Communications" in Chapter 2.

Print Quality Problems

If the labels are not being printed properly, check the following table to locate the symptom and correct the problem.

Print Quality Problems

Symptom	Possible Causes	Solution
Blotches printing on labels.	Dirty printhead.	Clean the printhead. For help, see “Cleaning the Printhead” in Chapter 3.
	Dirty media path or rollers.	Clean the media path. For help, see “Cleaning the Media Guides and Media Path” in Chapter 3.
	Poor quality label or ribbon stock.	Use only Intermec label and ribbon stock to ensure superior print quality and product performance.
Printing is too light or too dark.	Incorrect darkness adjust control setting.	Adjust the control to achieve the best print quality. For help, see “Adjusting the Print Darkness” in Chapter 5.
	Incorrect media sensitivity setting.	Change sensitivity setting to match the type of media you are using (for help, see “Setting the Media Sensitivity Number” in Chapter 1). If you set the sensitivity setting correctly, try changing the dark adjust.
	Poor quality label or ribbon stock.	Use only Intermec label and ribbon stock to ensure superior print quality and product performance.
	Dirty printhead.	Clean the printhead. For help, see “Cleaning the Printhead” in Chapter 3.
Printing not aligned on label.	Printer is misfeeding media.	Make sure you have correctly installed the media. For help, see “Loading Media Into the Printer” in Chapter 1.
Labels are not stopping at the right point for removal.	Incorrect label rest point setting.	Adjust the label rest point. For help, see the PrintSet online help or the <i>IPL Programming Reference Manual</i> .
Print quality is poor.	Incorrect media sensitivity setting.	Change sensitivity setting to match the type of media you are using. If you set the sensitivity setting correctly, try changing the print darkness. For help, see the PrintSet online help or the <i>IPL Programming Reference Manual</i> .
	Incorrect darkness control setting.	Adjust the darkness adjust control. For help, see “Adjusting the Print Darkness” in Chapter 5.
	Print speed exceeds the capability of the media.	Lower the print speed or use Intermec media recommended for the print speed.
	Printhead, platen roller, or label path are dirty.	Clean printhead, platen roller, and label path as described in Chapter 3, “Maintaining the Printer.”

Print Quality Problems (continued)

Symptom	Possible Causes	Solution
Print quality is poor. (continued)	Uneven print contrast (density).	Adjust the bias adjust screw. See “Correcting Uneven Print Quality” in Chapter 5.
	Poor quality label or ribbon stock.	Use only Intermec label and ribbon stock to ensure superior print quality and product performance.
	Ribbon wrinkling.	Check to make sure that you installed the ribbon correctly. For help, see “Loading Thermal Transfer Ribbon” in Chapter 1. Adjust the bias adjust screw. See “Correcting Uneven Print Quality” in Chapter 5.
	Ribbon installed upside down.	Make sure you installed the ribbon correctly. For help, see “Loading Thermal Transfer Ribbon” in Chapter 1.
	You are using the wrong core-locking bracket on the ribbon hub.	Use the plastic core-locking brackets for plastic core ribbons and the cardboard core-locking brackets for cardboard core ribbons. For help, see “Loading Thermal Transfer Ribbon” in Chapter 1.
	Direct thermal/thermal transfer switch set in the wrong position.	Set the switch for the type of media you are using. For help, see “Loading Media Into the Printer” in Chapter 1.
	You have exceeded the maximum recommended print speed.	Reduce the print speed.
The printer skips labels randomly or sends an intermittent error.	Media may be slipping against the platen roller causing the printing to compress.	Switch to approved media or clean the printhead and platen roller as described in Chapter 3, “Maintaining the Printer.”
	The label format extends beyond the label length.	Edit the format to ensure that the text fits on the label.
The printer skips labels randomly or sends an intermittent error.	The label gap sensor is not in the correct position.	Properly position the label gap sensor. For help, see “Adjusting the Label Gap Sensor” in Chapter 5.
	The top of form position is not adjusted properly.	Use the top of form switch to adjust the top of form position. For help, see “Fine-Tuning the Top of Form Position” in Chapter 5.
Continuous media fault light.	The label mark sensor is not in the correct position.	Properly position the label mark sensor. For help, see “Adjusting the Label Mark Sensor” in Chapter 5.

Communication Problems

If the printer is not receiving downloaded data, try the solutions in the following table.

Communications Problems

Symptom	Possible Causes	Solution
Printer does not communicate with the host.	Serial port is incorrectly configured.	Make sure the printer's serial port settings match those of the host. Print a software test configuration label as explained in "Using Test and Service Mode Procedures" in Chapter 6 to check the serial port settings.
	Damaged or incorrect I/O cable.	Check the connections at both ends or replace the cable. See Appendix C for cable information.

Preventing Data Loss

Several problems can cause data loss or communications problems on the printer. Data loss can result in printing errors or missing field data.

The printer is a serial ASCII device. It communicates with the host through an ASCII serial communications I/O port. Hardware handshaking involves the use of a hardware wire. Software handshaking involves a two-way datalink between the devices. The two devices communicate with each other without losing data through the use of handshaking. The printer sends both forms of handshaking simultaneously when the printer's input buffer is full. Any loss of data can cause printing errors or missing data.

Hardware handshaking uses pins 11 or 20 of the RS-232 interface to control data flow. When the printer is using Intermec Standard protocol, it holds pins 11 and 20 high when it is ready to receive data. The printer holds the pins low when it is in one of the following conditions:

- Buffer full
- Ribbon fault
- No label stock
- Label at strip pin

The printer uses XON/XOFF protocol for software handshaking. When the input buffer is full, the printer transmits an XOFF character. This character alerts the host to the fact that the printer buffer is full and cannot receive any more data. When the printer is ready to receive more data, it sends the XON character.

To check for communications problems

- 1** Check the cabling from the printer to the host system.
- 2** Check the communications interfacing of the devices connected to the printer.
- 3** Check the printer for proper electrical operation of the I/O port.
- 4** Ensure the host system is not overrunning the printer input buffers.
- 5** Ensure the data string being sent to the printer contains the correct information.



5 Optimizing Printer Performance

This chapter explains how to optimize and maintain print quality. This chapter covers these topics:

- Correcting uneven print quality
- Adjusting the print darkness
- Fine-tuning the top of form position
- Adjusting the label gap sensor
- Adjusting the label mark sensor
- Using the printer memory efficiently
- Increasing throughput

Optimizing and Maintaining Print Quality

Intermec designed and configured the printer to provide the best possible print quality for both direct thermal and thermal transfer media. If necessary, you can manually adjust the printer to perform registration tasks such as correcting uneven print quality.

Correcting Uneven Print Quality

You may experience problems in print quality (ribbon wrinkling or light print on one side of the label) if the printhead is not making even contact with the label stock. This condition can happen with any size label stock, but is most common when using narrow label stock.

To achieve the best print quality, adjust the bias adjust screw each time you use media of a different width.



Note: You must properly adjust the bias adjust screw to prevent premature printhead failure and excessive platen wear.

To adjust the bias adjust screw

- 1 Remove the media cover and locate the bias adjust screw.

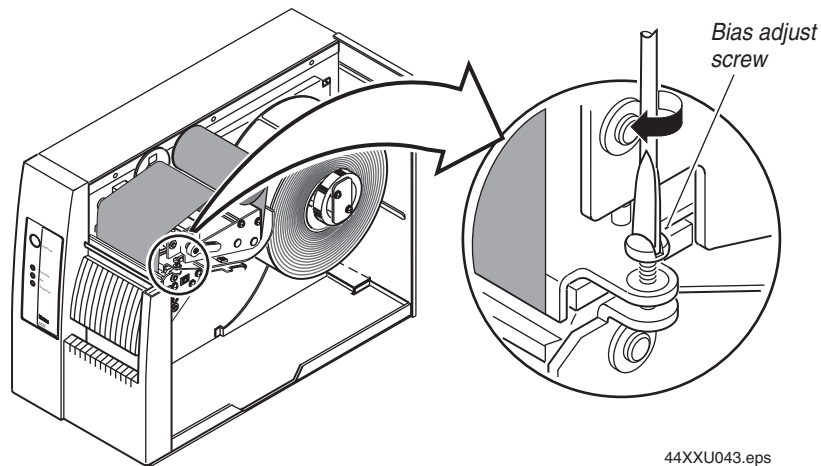

- 2 To compensate for uneven print quality, use a straight-slot screwdriver to turn the bias adjust screw as shown.

Adjusting the bias adjust causes the printhead to rest evenly on the drive roller and results in even print quality.

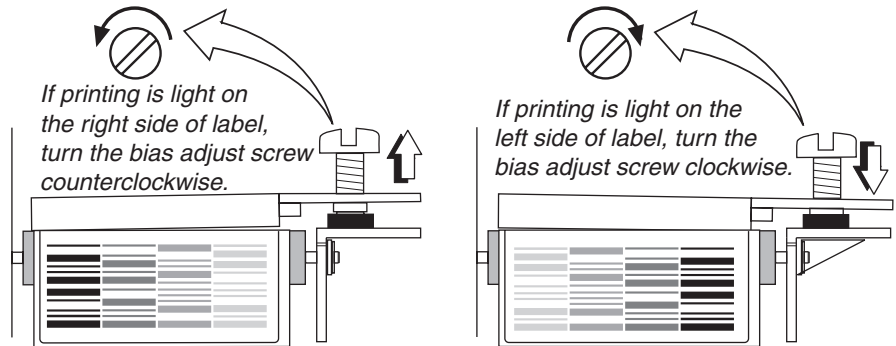

44XXU044 .eps

- 3 Replace the media cover.

Adjusting the Print Darkness

Use the darkness adjust control in combination with the Print Darkness adjustment in PrintSet to fine-tune the darkness of print on the labels. The fine adjustments compensate for variations in the media (“lot to lot”), the printhead, or the printer. Set the darkness adjust control after you enter the media sensitivity number.

For the best results in adjusting the print darkness (energy to the printhead), perform these procedures in order:

- 1 Set the correct sensitivity number.
- 2 Adjust the manual darkness adjust control on the back of the printer.
- 3 Adjust the Print Darkness setting in PrintSet.

To adjust the manual darkness adjust control

- 1 Locate the darkness adjust control on the back of the printer.
- 2 Use a small straight-slot screwdriver to adjust the print darkness:
 - To increase the print darkness, turn the control clockwise.
 - To decrease the print darkness, turn the control counterclockwise.

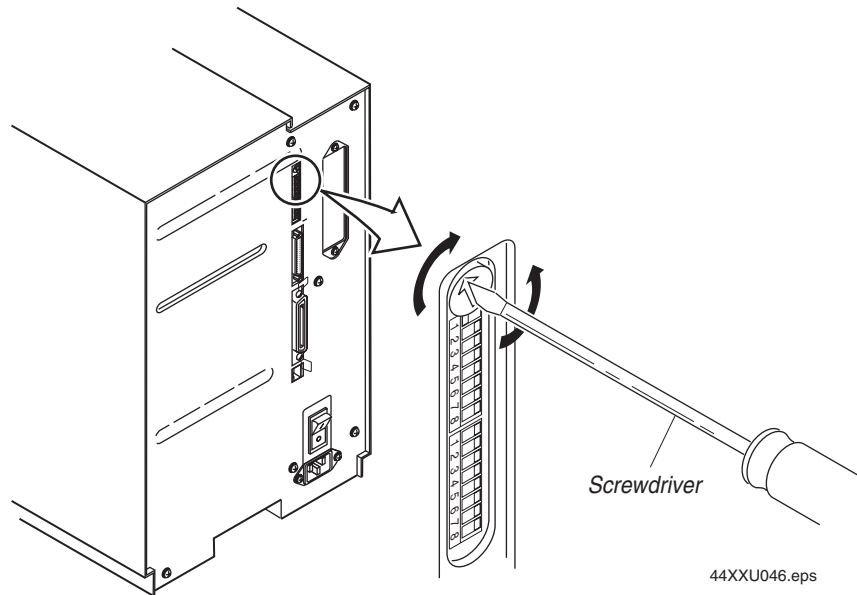

The print darkness adjust in PrintSet is similar to the dark adjust available on a copier. An increase in print darkness increases the energy to the printhead and results in darker print. A decrease in print darkness decreases the energy to the printhead and results in lighter print.

To adjust the print darkness with PrintSet

- 1 Start PrintSet on your PC.
- 2 Click the Media Type button:



The Media Type dialog box appears.

- 3 On the Print Quality Setup tab, adjust the Print Darkness slider bar until the setting that you want appears underneath it.

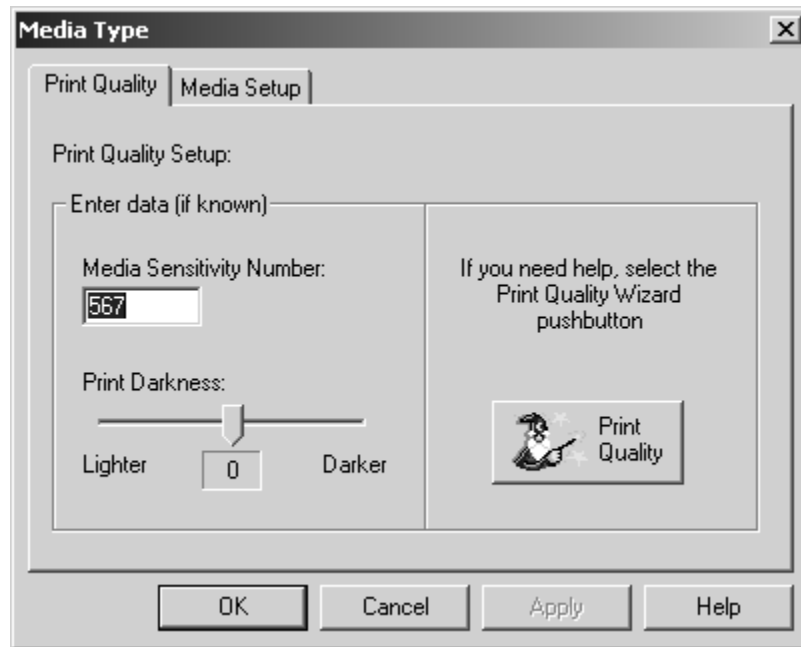

You can adjust the print darkness from +10 to -10.

- 4 Click OK.
- 5 Download your change to the printer by pressing the button to send command updates to the attached printer.



Fine-Tuning the Top of Form Position

If the label format prints too close to the front or back edge of the label, you can fine-tune the position with the top of form (TOF) switch. The TOF switch controls the position of the format forward or backward along the length of the label.

Only use the TOF switch to fine-tune the label format position after you design the label. Use PrintSet or the IPL top of form command to control the default TOF setting. For help on using the top of form command, see the PrintSet online help or the *IPL Programming Reference Manual* (P/N 066396).

The printer returns to the default TOF setting when you

- cycle printer power.
- lift the printhead.

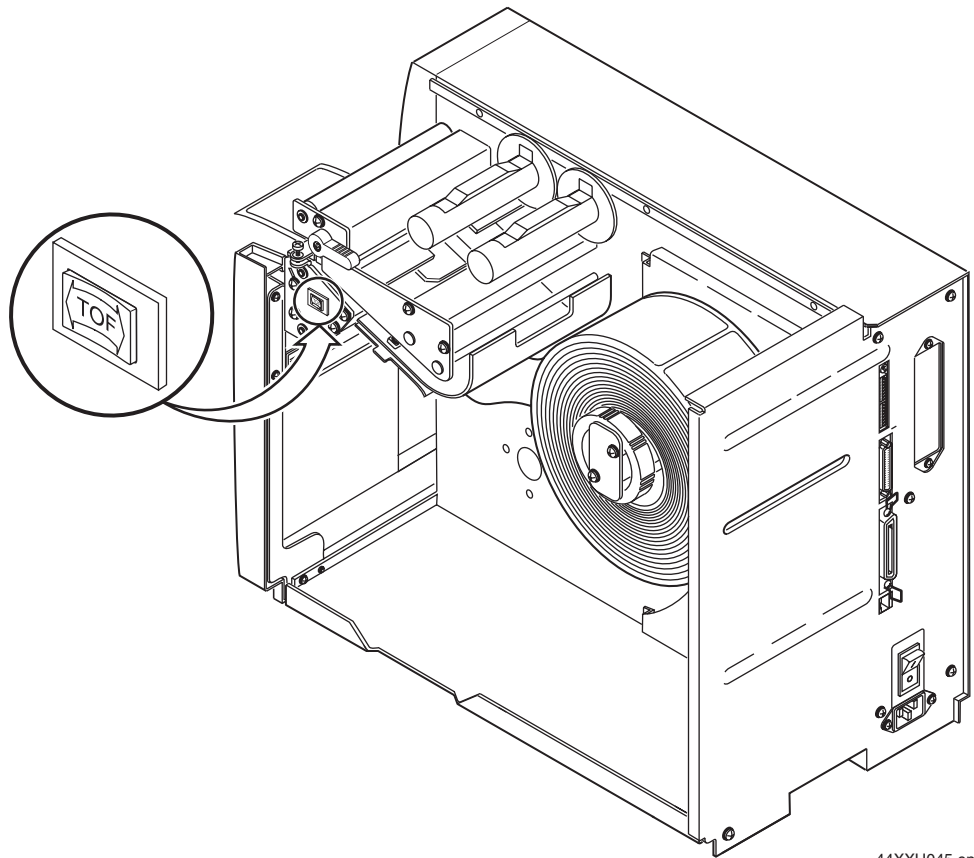

44XXU045.eps

TOF switch: The TOF switch is a small rocker switch located on the lower outboard plate of the printer.

To move a label format backward with the TOF switch



Note: You will see the new format position on the second label you print after pressing the TOF switch.

You notice that the format is printing toward the front part of the label.



44XXU047.eps

- 1 Remove the media cover.



Note: Do not raise the printhead while adjusting the TOF position.

- 2 Press on the back part of the TOF switch. Each time you press the TOF switch, you move the label format backward 0.127 mm (0.005 in).

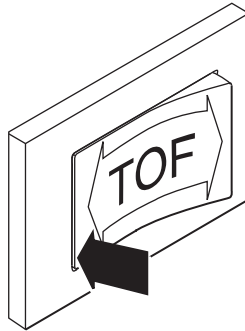

44XXU059.eps

- 3 Press the TOF switch repeatedly until the format moves backward to the correct position on the label.

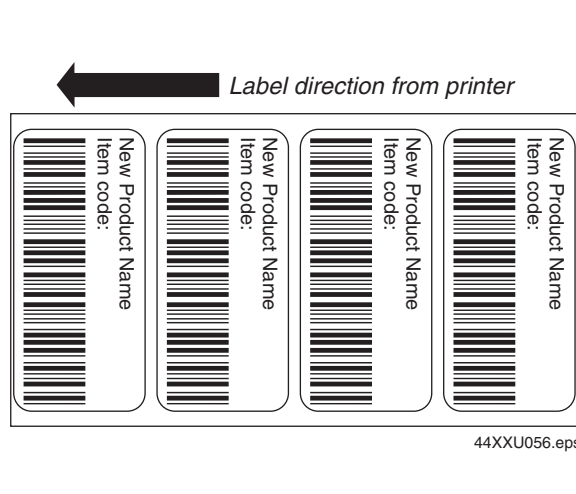

44XXU056.eps

To move a label format forward with the TOF switch

You notice that the format is printing toward the back part of the label.

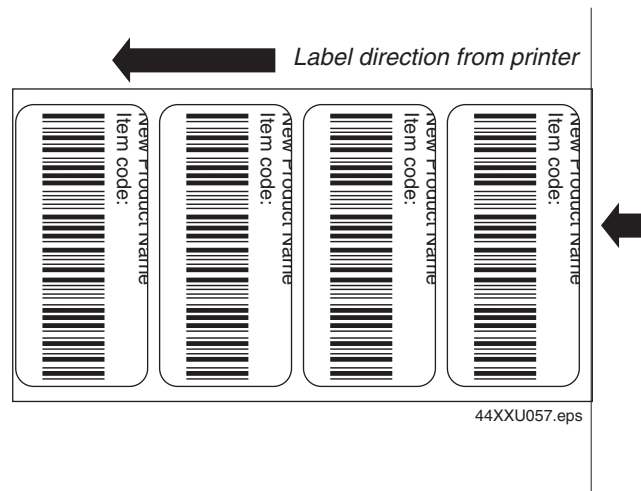

- 1 Remove the media cover.



Note: Do not raise the printhead while adjusting the TOF position.

- 2 Press on the front part of the TOF switch. Each time you press the TOF switch, you move the label format forward 0.127 mm (0.005 in).
- 3 Press the TOF switch repeatedly until the format moves forward to the correct position on the label.

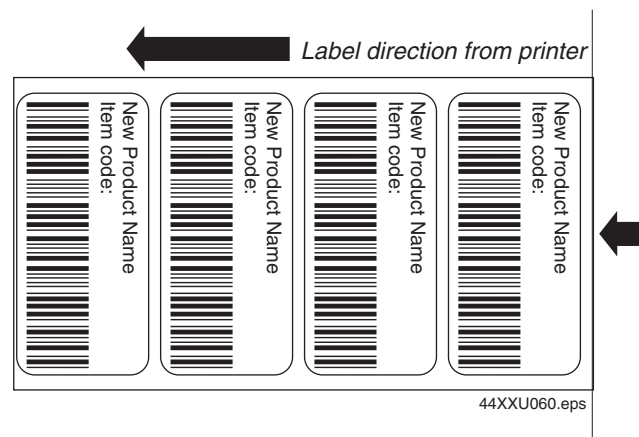

Adjusting the Label Gap Sensor

If you experience problems such as the printer skipping labels or the printer stopping and the yellow LED flashing, you may need to adjust the label gap sensor. You are most likely to experience any of these problems if you are using very narrow label stock and the label gap sensor is not in the correct position. You can adjust the label gap sensor from 0 to 2.5 cm (0 to 1.0 in) from the inner edge of the printer.



Note: Intermec sets the label gap sensor to 1.3 cm (0.5 in) from the inner edge of the printer at the factory. You should be able to leave it in this position for most labels wider than 2.5 cm (1.0 in).

To adjust the label gap sensor

- 1 Remove the media cover.
- 2 Turn the label gap sensor knob approximately 1/2 turn counterclockwise to free the sensor for adjustment.
- 3 Slide the label gap sensor knob to the position where the label gap sensor is optimized for the label stock.

Here are some guidelines for you to follow:

- If the labels are less than 2.5 cm (1.0 in) wide, position the label gap sensor in the middle of the label.
- If the labels are greater than 2.5 cm (1.0 in) wide, position the label gap sensor over the straight edge of the label (not over the label radius).

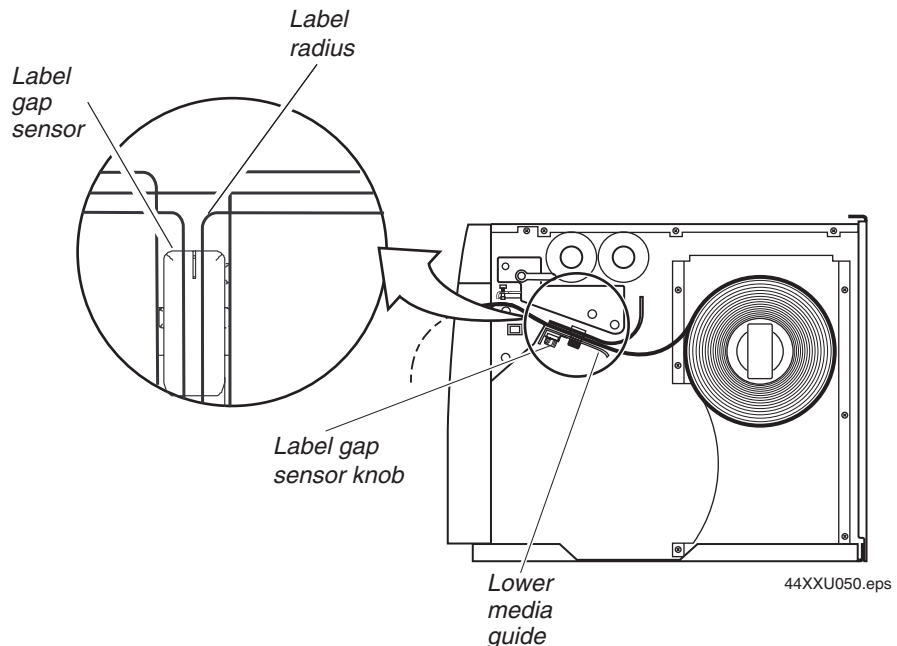

- 4 Turn the label gap sensor knob clockwise to secure it in the new position.
- 5 Try printing a label to see if the printer is detecting the start of the label (top of form).
- 6 If the printer is still not detecting the top of form, slide the label gap sensor a little further toward the outer edge of the lower media guide.
- 7 Replace the media cover.

Adjusting the Label Mark Sensor

The label mark sensor detects the black mark on the back of continuous media stock. The printer uses the output to determine the start of print. The label mark sensor is behind the platen roller and near the inboard edge of the printer. You can position the label mark sensor no more than 6.35 cm (2.5 in) from the inboard edge of the printer.

To adjust the label mark sensor

- 1 Remove the media cover and locate the label mark sensor.
- 2 Use your index finger to slide the label mark sensor to the correct position for the media. You can position the label mark sensor anywhere from the inboard edge of the printer to the center of the paper path.

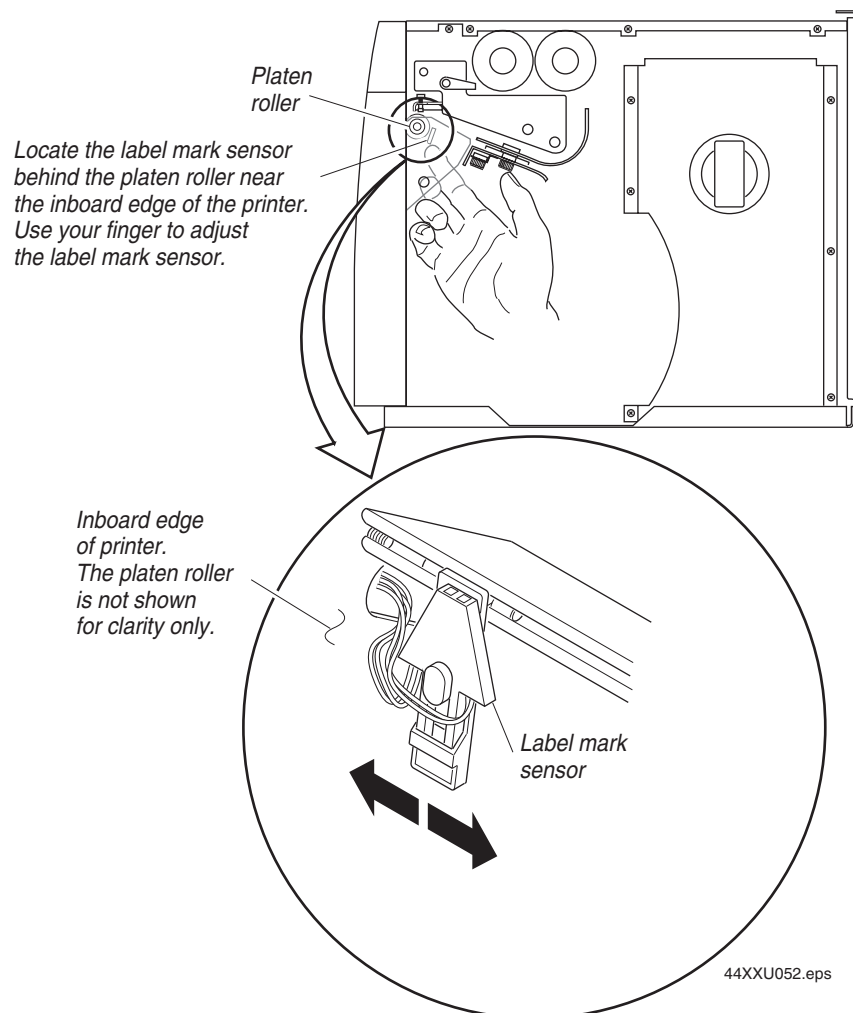

- 3 Print a few labels to make sure that the label mark sensor is detecting the black mark on the media.
- 4 Replace the media cover.

Using the Printer Memory Efficiently

To receive the best performance from the printer, you must understand how to use the printer memory. The following sections can help you determine the most efficient way to use the printer memory.

How Is the Printer Storage Memory Used?

There is enough storage memory in the printer to store several different label formats and still retain enough memory to store downloaded fonts, graphics, and data. Be careful of how you use the printer memory.

The printer uses flash memory for storing tables, pages, formats, fonts, and user-defined characters (UDCs). The 4420 and 4440 printers have 128K of flash memory available for storage. If you require additional storage memory, you can purchase flash SIMM for the printer.

The printer supports these parameters independent of the amount of memory installed or allocated by the printer:

- Maximum number of formats: 99 (You can edit formats 1 to 99. You cannot edit default format 0.)
- Fields per format: 200
- Maximum data buffer size for a field: 3550
- Maximum number of UDCs: 100
- Maximum number of user-defined fonts: 16

Making the Most of the Memory

There are limits to the number of formats, fonts, graphics, or pages that you can store in the printer. You can define up to 16 fonts, but there may not be enough room depending on the amount of memory being used for other purposes. The more formats, graphics, and fonts you store, the less memory is available.

When you run into a memory usage problem, use PrintSet to see how much memory remains available. You must upload the memory information from the printer first. Refer to the PrintSet online help for more information.

If you find that it is necessary to increase the available memory, you can do one of the following:

- Increase the amount of available memory by using the Memory Reset portion of the Test and Service menu. See “Using Memory Reset” in Chapter 6 for more information.
- Delete any unneeded user-defined fonts, graphics, pages, or formats. For help, see the PrintSet software or the *IPL Programming Reference Manual*.

- Purchase additional memory. Contact your local Intermec representative for information on purchasing additional memory for the printer.

Increasing Throughput

To print labels as quickly as possible, you must adjust the print speed in conjunction with the number of image bands (one image band equals 1 inch of label). The print speed and image band settings determine the rate at which the printer processes the images of the labels. This rate in turn affects the throughput of the entire printing process.

The printer begins imaging the label as soon as it receives the command to select a format. Since the printer starts imaging the label so early, the chance that the imaging process will be unable to keep up with the print speed decreases and throughput improves. However, if the number of image bands is too low, the imaging process is unable to keep up with the print speed. In this case, the printer stops printing and starts again at the lowest print speed with the maximum number of image bands. If the image band command is set too high, the printer spends more time than necessary imaging and slows down label production.

What Is an Image Band?

Image bands are a section of memory where a picture of a label format is drawn. This drawing process is known as imaging. Once the picture is imaged, the printer loads the picture from the image bands to the printhead for printing. Each image band is equal to 1 inch of length of the label format. The number of image bands you use may be less than the length of the label you are printing. The number of image bands (in inches) does not have to equal the length of the label since the printer recycles the image bands. Once the contents of an image band have been printed, it may be reused to image the next section of the label.

Keep in mind that the more complex the label, the longer it will take to image each section, thus requiring a slower print speed. To use a higher print speed, use more image bands to allow more of the imaging process to complete before printing begins.

How the Image Bands Command Works

The image bands command controls the amount of memory allotted to the imaging process. When you increase the image band adjustment to a higher number, you add more buffers to the imaging memory. By doing this, more of the label format is imaged before printing begins.

The minimum number of required image bands is dependent upon the print speed and the complexity of the label. Labels that contain numerous fields with different rotations, graphics, or combinations of these formatting options may require a higher number of image bands.

To set the number of image bands, use PrintSet or the IPL command. For help, see the PrintSet online help or the *IPL Programming Reference Manual*.

Optimizing Print Speed and Image Band Setting

The maximum number of image bands available for use is 20 bands. The minimum number of image bands available is 2.

To optimize the number of image bands for your print speed

- 1 Set the image band setting at the lowest number (2).
- 2 Print a label at the desired speed.

If the label prints, the image band setting is optimal. You do not need to perform any more adjustments.

If the number of image bands is too low, the printer aborts the label before printing is completed and attempts to reprint the label at the slowest speed (2 ips) with the highest number of image bands (20). You need to continue with Step 3.

- 3 Return to the original print speed and increase the original number of image bands one at a time.

Continue to increase the number of image bands until the printer prints a label correctly.

If the printer still aborts and reprints at the highest image band setting, you may be trying to optimize at a print speed that is too high for the label format. Try optimizing the number of image bands at a lower print speed or add an expansion DRAM SIMM.

To print very complex labels at high speeds, you must allocate enough image bands to completely image the label before printing. Allocate one band for each inch of label length. By doing this, you can print at any speed. However, there may be a considerable delay between labels.



6 Using Test and Service Mode

This chapter explains the different procedures you can perform while the 4420 or 4440 printer is in Test and Service mode. This chapter covers these topics:

- How to use Test and Service mode
- Printing test labels
- Setting configuration commands

Using Test and Service Mode Procedures

When you press the Feed/Pause button, the current function pauses and the printer enters Test and Service mode and executes all Test and Service mode procedures. The printer remains in Test and Service mode until you turn off the power and reset the DIP switches.

To enter Test and Service mode

- 1 Turn off the printer.
- 2 Press and hold the Feed/Pause button while turning on the power.
The printer prints out a hardware configuration label and then enters Data Line Print mode.
- 3 Set the DIP switches to the test or service function you wish to perform. See the following table for a list of the DIP switch settings.
- 4 Press the Feed/Pause button. The test begins immediately.
- 5 If you want to perform another function, change the DIP switch settings and press the Feed/Pause button.

The function the printer is currently executing terminates, and the printer performs the new function.

To exit Test and Service mode

- 1 Turn off the printer.
- 2 Reset the DIP switches to their original settings.
- 3 Turn on the printer.

Use the information in the following table to set the DIP switches for the appropriate Test and Service mode function you want to perform.

	Top Bank								Bottom Bank							
	OFF								ON							
TESTS	1	2	3	4	5	6	7	8	1	2	3	4	5	6	7	8
Test Prints	O O O															
Configurations	O O O															
Hardware*									O O							
Software									1 O							
Test Labels	1 O O															
Print Quality									O O							
Pitch									1 O							
Page	O 1 O O O															
Single Page									N N N N N							
All Pages									1 1 1 1 1							
Format	1 1 O O O															
Single Format									N N N N N N N							
All Formats									1 1 1 1 1 1 1							
UDC	O O 1 O O															
Single UDC									N N N N N N N							
All UDCs									1 1 1 1 1 1 1							
Font	1 O 1 O O															
Single Font									N N N N N N							
All Fonts									1 1 1 1 1 1							
Data Line Print	*1 O O O O O O O															
Selective Transfer	1 1 O															
Send Pages	1 O O															
Single Page									S S							
All Pages									1 1							
Send Format	O 1 O															
Single Format									S S							
All Formats									1 1							
Send UDC	1 1 O															
Single UDC									S S							
All UDCs									1 1							
Send Font	O O 1															
Single Font									S S							
All Fonts									1 1							
Send Configuration	1 O 1															
Send Tables	O 1 1															
Send All	1 1 1															
Memory Reset	O O 1															
Page/Format	O O O															
UDC/Font	1 O O															
Configuration	O 1 O															
Tables	1 1 O															
All	1 1 1															

Q: OFF = Batch of 1. ON = Batch of 100.
 N: Page/Format/UDC/Font number. Least significant bit is switch 8.
 S: Source Page/Format/UDC/Font number. Least significant bit.
 D: Destination Page/Format/UDC/Font number. Least significant bit.

Default settings are noted with an *

44XXU061.eps

Test and Service mode DIP switch settings: This illustration shows DIP switch settings for Test and Service mode functions.

Printing Test Labels

The 4420 or 4440 printer can print a variety of test print labels that provide you with information about the printer configuration and the quality of the printing.

To print a test label

- 1 Turn off the printer.
- 2 Press and hold the Feed/Pause button while turning on the printer.
The printer prints out a hardware configuration label and then enters Data Line Print mode.
- 3 Set the DIP switches to print out the test label of your choice: software, print quality, or pitch. Refer to the Test and Service DIP Switch Settings table for the correct settings.
- 4 Hold the Feed/Pause button down until the printer starts printing.
The printer begins printing out the test label immediately.
- 5 Exit Test and Service mode by turning the printer off and returning all DIP switches to their original settings.

Using Data Line Print Mode

Use Data Line Print mode to troubleshoot communications between the printer and host and to test the operation of the printer. When the printer is in Data Line Print mode, it prints all downloaded data with the hexadecimal equivalent directly underneath it. Hold the Feed/Pause button down momentarily to suspend the test. Press the Feed/Pause button longer to transmit the firmware program and version number to the host.

To enter Data Line Print mode

- 1 Turn off the printer.
- 2 Press down and hold the Feed/Pause button while turning on the printer.

The hardware configuration test label is printed. You are now in Data Line Print mode.

Performing Selective Transfer

If you want to copy select formats, pages, fonts, or graphics to another printer but you do not want to clone the entire RAM contents, use the selective transfer command. Use this command to set up different printers to print the same label formats.

Using the selective transfer command, you can download the following label design attributes from one 4420 or 4440 printer to another:

- Any specified page or all pages
- Any specified format or all formats
- Any specified font or all fonts
- Any specified user-defined character (UDC) or all UDCs

Set the serial port DIP switch settings to 115,200 baud, even parity, 1 stop bit, and 8 data bits. If you are transferring pages or fonts, the destination and source numbers can be different. If you are transferring formats or UDCs, the destination and source number must be the same.

To perform selective transfer

- 1** Turn off the sending and receiving printers.
- 2** Set the serial port on both the sending printer and the receiving printer to 115,200 baud, even parity, 1 stop bit, and 8 data bits.
- 3** Turn on the receiving printer.
- 4** Press down and hold the Feed/Pause button while turning on the printer. The hardware configuration test label prints.
- 5** Connect the serial ports of the sender and receiver ports together with an RS-232 null modem cable. For help, refer to “Connecting the Printer to Your System” in Chapter 2 and “Communications Interfaces” in Appendix C.
- 6** Set the DIP switches on the sending printer and receiving printer for selective transfer as shown in the Test and Service mode DIP switch settings illustration earlier in this chapter.
- 7** Select the type of data that you wish to transfer (such as pages, formats, fonts, or UDCs) by setting the corresponding DIP switches shown in the Test and Service mode DIP switch settings illustration earlier in this chapter.
- 8** Press the Feed/Pause button on the sending printer to initiate selective transfer. When the Power/Data LED stops flashing, the selective transfer is complete.
- 9** Exit Test and Service mode by turning off the printer and returning all DIP switches to their original settings.

Using Memory Reset

Use memory reset if you want to return the printer to its default configuration or if you need to increase the amount of memory available in the printer. You can also use memory reset to clear pages and formats, user-defined characters and fonts, configurations, tables, or all of these parameters.

To use memory reset

- 1 Turn off the printer.
- 2 Set the DIP switches to reset a portion or all of the memory by using the Test and Service mode DIP switch settings illustration earlier in this chapter.
- 3 Press and hold the Feed/Pause button while turning on the printer. The printer prints out a hardware configuration test label.
- 4 Hold the Feed/Pause button down for 1 second. The printer resets a portion or all of its memory.
- 5 To exit Test and Service mode, turn off the printer.
- 6 Reset the DIP switches to their original setting and then turn on the printer.



Note: You can also use the Test and Service command (D) to reset all printer RAM.

Setting Configuration Commands in Test and Service Mode

Test and Service mode gives you with another way to change configuration commands besides sending them down from the host. You can change these commands by setting the Test and Service mode DIP switches:

- Label rest point
- Emulation mode
- X forms adjust
- Y forms adjust

	Top Bank								Bottom Bank							
	OFF								ON							
	1	2	3	4	5	6	7	8	1	2	3	4	5	6	7	8
Label Rest Point	O	1	1													
Adjust Forward					O				N	N	N	N	N			
Adjust Backward					1				N	N	N	N	N			
Emulation	1	O	1													
5.0 mil Advanced mode					O	O										
10 mil 86XX mode					1	O										
15 mil 86XX mode					1	1										
X Forms Adjust	1	1	1	1												
Adjust Forward								O								
Adjust Backward								1	N	N	N	N	N			
Y Forms Adjust	1	1	1	O					N	N	N	N	N			

N: Number. Least significant bit first.

44XXU062.eps

Configuration DIP switch settings: This illustration shows the Test and Service mode DIP switch settings for changing the configuration commands.

Setting the Number of Dot Increments

You can move the label rest point and X forms adjust configuration commands forward or backward by setting the printer DIP switches. Use the top bank of DIP switches to determine whether the movement is forward or backward. Use the bottom bank of DIP switches to set the number of dot increments for label rest point, X forms adjust, and Y forms adjust. The printer moves in 5 mil increments or 0.005 inch per dot.

Bottom Bank

0 = OFF
1 = ON

OFF

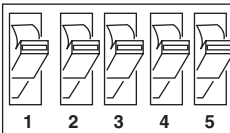

ON

1 2 3 4 5

# of Dot Increments	1	2	3	4	5
1	1	0	0	0	0
2	0	1	0	0	0
3	1	1	0	0	0
4	0	0	1	0	0
5	1	0	1	0	0
6	0	1	1	0	0
7	1	1	1	0	0
8	0	0	0	1	0
9	1	0	0	1	0
10	0	1	0	1	0
11	1	1	0	1	0
12	0	0	1	1	0
13	1	0	1	1	0
14	0	1	1	1	0
15	1	1	1	1	0
16	0	0	0	0	1
17	1	0	0	0	1
18	0	1	0	0	1
19	1	1	0	0	1
20	0	0	1	0	1
21	1	0	1	0	1
22	0	1	1	0	1
23	1	1	1	0	1
24	0	0	0	1	1
25	1	0	0	1	1
26	0	1	0	1	1
27	1	1	0	1	1
28	0	0	1	1	1
29	1	0	1	1	1
30	0	1	1	1	1

44XXU063.eps

Dot increments DIP switch settings: This illustration shows the dot increment settings for the bottom bank of switches. See the previous illustration, Configuration DIP switch settings, for the top bank DIP switch settings.

To set the number of dot increments

- 1 In the top bank, turn the appropriate switches on or off for forward or backward movement. See the Configuration DIP switch settings illustration earlier in this chapter for the appropriate DIP switch settings.

- 2 See the previous illustration of the Dot increments DIP switch settings. Scan down the # of Dot Increments column until you reach the number of dot increments you want to adjust the command forward or backward.
- 3 In the bottom bank, turn on the switches that have a 1 in their column. Turn off all other switches.
- 4 Press the Feed/Pause button and the printer prints out the software configuration label and stops at the new location.

For example, you print a label and discover that it does not extend far enough from the tear bar. You need to move the label rest point forward 10 dot increments (0.05 inch) so that the printer feeds more label out when it finishes printing. Find 10 in the # of Dot Increments column. It shows a 1 in the columns of DIP switches 2 and 4, and a 0 in the columns of 1, 3, and 5. The 1 tells you to turn on the switch. The 0 tells you to turn off the switch. Turn on switches 2 and 4. Turn off all other switches.

Adjusting the Label Rest Point

The Label Rest Point configuration command adjusts the point at which the printer presents each label for removal. Use this command in conjunction with self-strip applications. The label rest point adjust range is from -30.5 mil increments (farthest back) to +30.5 mil increments (farthest forward). Use a negative number if you want the printer to retract the label a number of dot increments after it prints the label. Use a positive number if you want the printer to feed the label a number of dot increments after it prints the label.

There are three ways to adjust the label rest point:

- You can use the Test and Service DIP switch bank. Follow the procedure below to use the DIP switch settings to adjust the label rest point.
- You can set it by using the PrintSet application software. See the Paper Handling portion of PrintSet for more information.
- You can use the IPL command. See the *IPL Programming Reference Manual* (P/N 066396) for more information.

To adjust the label rest point

- 1 Turn off the printer.
- 2 Press and hold the Feed/Pause button while turning on the printer.
The printer prints out a hardware configuration label and then enters Data Line Print mode.

- 3 In the top bank of the Test and Service mode DIP switches, turn off switch 1 and turn on switches 2 and 3.

To adjust the label rest point forward (feed more label), turn off DIP switch 4.

To adjust the label rest point backward (retract label), turn on DIP switch 4.

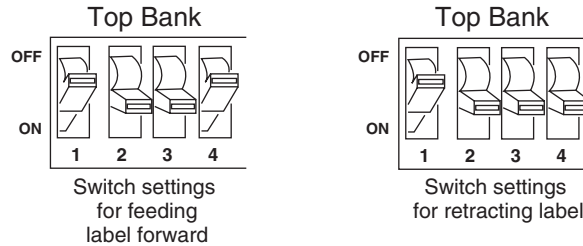

44XXU064.eps

- 4 In the bottom bank of the Test and Service mode DIP switches, turn on or off the appropriate DIP switches. See the Dot increments DIP switch settings illustration earlier in this chapter.
- 5 Press the Feed/Pause button.
The printer prints out the software configuration label and stops at the new location.
- 6 Verify that the Label Rest Point number on the software configuration label matches the number you set in Step 4.
- 7 Try printing again to see if you need to readjust the DIP switches in the bottom bank.
- 8 If you need to readjust the DIP switches in the bottom bank, repeat Steps 4 through 6. If not, exit Test and Service mode by turning off the printer, returning all DIP switches to their original settings, and turning on the printer.

Setting Emulation Mode

If you are replacing an Intermec 8636 or 8646 printer with a 4420 or 4440 printer, you can keep your existing network, hardware, software, and label formats by using Emulation mode. The labels the 4420 or 4440 printer produces will look just like the labels that the 86XX printer prints.

There are three ways to set the printer to Emulation mode:

- Use the DIP switches in the Test and Service DIP switch bank. For help, see the following procedure.
- Use PrintSet to select either 100 dpi (10 mil) or 66 dpi (15 mil) mode. For help, see the PrintSet online help.
- Use the IPL command set to select Emulation mode. For help, see the *IPL Programming Reference Manual*.

To set the printer to Emulation mode using DIP switches

- 1 Upload label formats, fonts, and graphics from the 8636 or 8646 printer to the host computer.
- 2 Turn off the printer.
- 3 Disconnect the 86XX printer and install the 4420 or 4440 printer. See Chapter 2 for information on installing the 4420 or 4440 printer.
- 4 Press and hold the Feed/Pause button while turning on the printer. The printer prints out a hardware configuration label.
- 5 In the top bank of the Test and Service mode DIP switches, turn on switches 1 and 3 and turn off switch 2.
- 6 Use the table below to help you choose the appropriate DIP switch settings:

Setting	Description
86XX 10 mil	The printer emulates an 8636 or 8646 printer printing multiples of 10 mil (0.01 inch) drag and picket bar codes.
86XX 15 mil	The printer emulates an 8636 or 8646 printer printing multiples of 10 mil (0.01 inch) drag and picket bar codes.
Advanced 5 mil (4420 default)	The printer uses the 4420 command set and prints in multiples of 5 mil (0.005 inch) drag and picket bar codes.
Advanced 2.5 mil (4440 default)	The printer uses the 4440 command set and prints in multiples of 2.5 mil (0.0025 inch) drag and picket bar codes.

- To enable 10 mil emulation, turn on DIP switch 4 and turn off DIP switch 5.
 - To enable 15 mil emulation, turn on DIP switches 4 and 5.
 - To enable 5 mil Advanced mode, turn off DIP switches 4 and 5.
 - To enable 2.5 mil Advanced mode, turn off DIP switch 4 and turn on DIP switch 5.
- 7 Press the Feed/Pause button.
The printer prints out the software configuration label. Verify that the label states the correct mode.
 - 8 Turn off the printer.
 - 9 Reset the DIP switches to the original settings and then turn on the printer.
 - 10 Download the 86XX formats, fonts, and graphics from the host to the 4420 or 4440 printer.

Using Forms Adjust

If the label prints too close to one edge, you can reposition it by using the X forms adjust and Y forms adjust features. The X forms adjust controls the position of the printing area along the length of the label. The Y forms adjust controls the position of the printing area along the width of the label.

The following illustration shows the default X and Y origins.

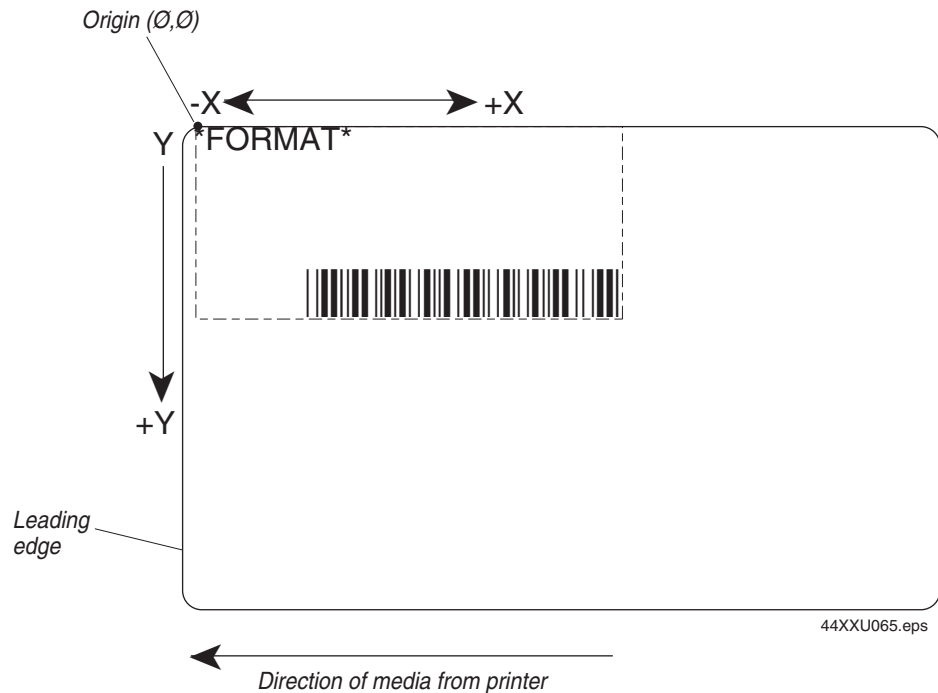

Default X and Y origins: This illustration shows the default X and Y origins. You can control the default X origin (top of form) with PrintSet or with the Test and Service DIP switches. You can control the default Y origin with the DIP switches only.



Note: An image printed on direct thermal media may have an X origin position, which is slightly different than the same image printed on thermal transfer media. Always use X forms adjust and Y forms adjust with the same media type that you plan to use for printing labels.

The default X origin is 0.10 inch (20 dot increments) from the leading edge of the label. You can move the X origin forward or backward 30 increments, where each increment is 5 mil.

The default Y origin is 0.00 inch from the edge of the label. You can move the Y origin down 30 increments, where each increment is 5 mil.

X Forms Adjust

Use the X forms adjust to control the position of the label format along the length of the label. When you move the X origin forward, the printer moves the format away from the leading edge of the label. When you move the X origin backward, the printer moves the format closer to the leading edge of the label. It is easier to use the TOF switch to move the origin forward or backward, but the printer will reset itself to the default position if you lift the printhead or cycle printer power.

To set the X forms adjust

- 1 Turn off the printer.
- 2 Press and hold the Feed/Pause button while turning on the printer.
The printer prints out a hardware configuration label and then enters Data Line Print mode.
- 3 In the top bank of the Test and Service mode DIP switches, turn on switches 1, 2, 3, and 4.

To move the X origin forward, turn off switch 5.

To move the X origin backward, turn on switch 5.

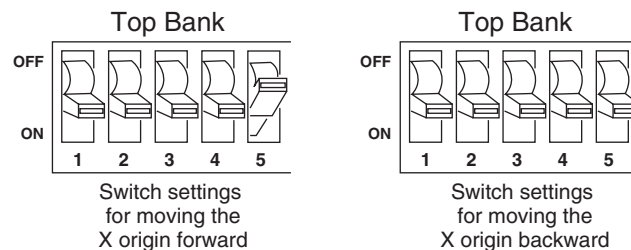

44XXU066.eps

- 4 In the bottom bank of the Test and Service mode DIP switches, set the DIP switches to the desired setting. See the Dot increments DIP switch settings illustration earlier in this chapter to see how to set the X forms adjust forward or backward a given number of increments.
- 5 Press the Feed/Pause button.
The printer prints out the software configuration label using the new X forms adjust setting.
- 6 Verify the X forms adjust number on the software configuration label matches the number you set in Step 4.

Y Forms Adjust

Use the Y forms adjust feature to control the position of the image in the direction parallel to the printhead. See the Dot increments DIP switch settings illustration earlier in this chapter for information on how to move the image forward a number of dot increments. If the label is too close to one edge of the printhead, you can adjust it using this feature.

To set the Y forms adjust

- 1** Turn off the printer.
- 2** Enter Test and Service mode by pressing down and holding the Feed/Pause button while turning on the printer. The printer prints out the hardware configuration label and then enters Data Line Print mode.
- 3** In the top bank of the Test and Service mode DIP switches, turn on switches 1, 2, and 3.
- 4** In the bottom bank of the Test and Service mode DIP switches, turn on or off the appropriate DIP switches. Refer to the Dot increments DIP switch settings illustration earlier in this chapter to see how to set the Y forms adjust forward or backward a given number of increments.
- 5** Press the Feed/Pause button. The printer prints out the software configuration label using the new Y forms adjust setting.
- 6** Verify the Y forms adjust number on the software configuration label matches the number you set in Step 4.



A Specifications

This chapter contains the following reference information:

- Specifications
- Factory default settings
- Printer options
- Supported bar code symbologies

4420 and 4440 Printer Specifications

This section describes the specifications and performance parameters for the 4420 and 4440 printers.

Dimensions (no options installed)

Height	41.9 cm (16.5 in)
Width	24.8 cm (9.75 in)
Length	43.8 cm (17.25 in)
Weight	19.35 kg (43 lbs)

Electrical Requirements

Input Voltage	100, 115, 200, or 230 VAC \pm 10%
Frequency	50-60 Hz
Current	2 or 1A

Environment

Operating	4°C to 40°C (40°F to 104°F)
Storage	0°C to 70°C (32°F to 158°F)
Humidity	10% to 90% with maximum wet bulb 82°F (28°C) and minimum dew point 36°F (2°C)

Character Sets

US ASCII	Norwegian/Danish
UK ASCII	Swedish/Finnish
German	Italian
French	Spanish
Switzerland	Code Page 850

Fonts and Graphics

There are 21 resident bitmap fonts (including OCR A and B) and three outline fonts available on the printers. You can use font ID 3 through 6 and 8 through 19 to download user-defined fonts.

Maximum UDF	102 mm square (4 in. square)
Maximum UDC	102 mm square (4 in. square)

Media Specifications

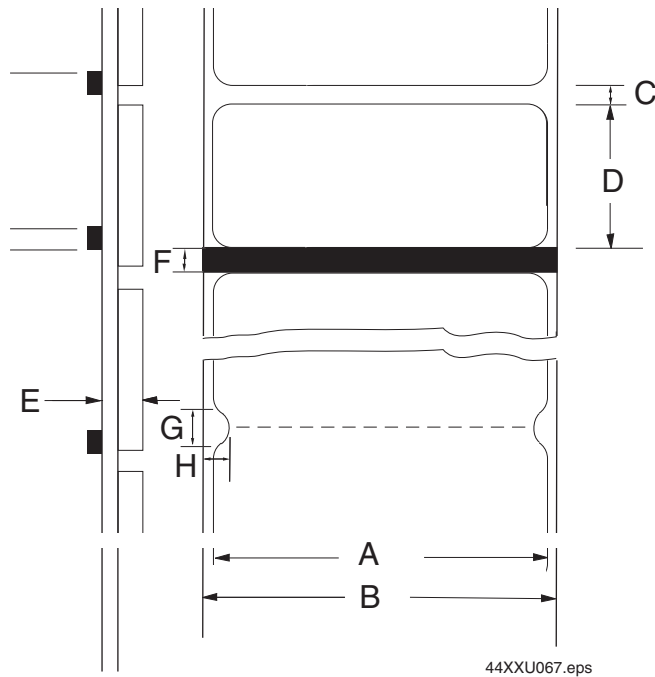

Media dimensions: This illustration shows to measure the media dimensions. See the next table, *Minimum and Maximum Media Dimensions*, for specific media dimensions.

Minimum and Maximum Media Dimensions

Letter	Description	Minimum	Maximum
A	Label width	16.5 mm (0.65 in)	111.8 mm (4.4 in)
B	Backing width (or tag width)	19 mm (0.75 in)	114.3 mm (4.5 in)
C	Gap between labels	2.54 mm (0.10 in)	25.4 mm (1.0 in)
D	Label length - self-strip media	25.4 mm (1.0 in)	609.6 mm (24 in)
	Label length - butt cut media	12.7 mm (0.5 in)	609.6 mm (24 in)
E	Media thickness (including backing)	0.08 mm (0.003 in)	0.30 mm (0.012 in)
F	Reflective sensor mark length	2.54 mm (0.1 in)	12.7 mm (0.5 in)
G	Notch length	2.54 mm (0.1 in)	3.2 mm (0.126 in)
H	Notch height (depth)	6.4 mm (0.25 in)	12.7 mm (0.5 in)
	Roll diameter		213 mm (8.38 in)

Memory

Base	Optional
1MB of DRAM	8 or 16 MB DRAM SIMM modules
128K of flash	8 to 16 MB Kanji/Katakana flash SIMM module

Printhead

4420

Width	112 mm maximum (4.4 in)
Printed dot size	0.127 mm (0.00492 in square)
Resolution	8 dots per mm (203 dots per in)
Number of elements	896 per printhead
“X” dimensions	10 mil to 500 mil (0.25 mm to 12.7 mm); 5 mil (0.13 mm) in drag mode only (specified media only)

4440

Width	112 mm maximum (4.4 in)
Printed dot size	0.065 mm (0.00246 in square)
Resolution	16 dots per mm (406 dots per in)
Number of elements	1792 per printhead
“X” dimensions	5 mil to 500 mil (0.127 mm to 12.7 mm) (specified media only); 2.5 mil (0.06 mm) in drag mode only (specified media only)

Printing Method

The printers are capable of direct thermal (DT) printing or thermal transfer (TTR) printing using a thermal transfer ribbon.

Printing Speed

Maximum	254 mm per second (10 inches per second), on specified media only
Minimum	51 mm per second (2 inches per second)

The print speed can be changed in 1 ips increments only. Note that the printer cannot print at 228.6 mps (9 ips).

Ribbon Specifications

Length	450 m (18,000 linear inches)
Widths	54 mm (2.1 inches) 76 mm (3.0 inches) 104 mm (4.1 inches) 114 mm (4.5 inches)
Diameter	81 mm (3.2 inches) maximum

Factory Default Settings

The following table lists the factory default settings for the 4420 and 4440 printer. Use PrintSet to set these parameters. The printer’s default serial port settings are described in Chapter 2, “Installing the Printer.”

Factory Default Settings

Configuration	Default Setting
Preamble Character	Disabled
Postamble Character	Disabled
Auto-Transmit 1	Disabled
Auto-Transmit 2	Disabled
Auto-Transmit 3	Disabled
Message Delay	0 milliseconds
Power-Up Mode	5 mil Advanced mode (4420) 2.5 mil Advanced mode (4440)
Cutter	Disabled
End-of-Print Skip Distance	100 dots (0.5 inches)
Top of Form	20 dots (0.1 inches)
Media Sensitivity	470 Direct Thermal/567 Thermal Transfer
Number of Image Bands	3
Maximum Label Length	1000 dots (5 inches)
Printer Character Set	US ASCII
Label Retract	Disabled
Label Retract Distance	0
Print Speed	3 inches per second (ips)
Label Stock Type	Die-cut
Intercharacter Delay	0 milliseconds
Storage Memory (standard)	128K flash

Printer Options

This section contains a list of all the options you can use with the 4420 and 4440 printer along with a brief description. Consult your local Intermec representative to order any option.

Communications Interfaces

You can order any of these field- or factory-installable communications interfaces for the printer.

EasyLAN 10i Interface

This option lets you connect the printer to a 10BaseT Ethernet network. Various network printing protocols are available. For more information, see the EasyLAN 10i documentation.

EasyLAN 10i2 Adapter

The external EasyLAN 10i2 Ethernet adapter (P/N 072885) and the internal EasyLAN 10i2 Ethernet adapter (P/N 072884) allow you to share your available printer resources with everyone on your Ethernet network. With the EasyLAN 10i2 adapter installed, the parallel port on the printer is not available for use. For more information, see the EasyLAN 10i2 documentation.

EasyLAN Wireless Option

The EasyLAN Wireless is an 802.11b radio option that lets the printer communicate wirelessly with a PC that contains an 802.11b radio card (ad-hoc network). It can also communicate with other devices via an access point (infrastructure network) in your data collection network. For more information, see the EasyLAN Wireless documentation.

Coax Interface

This option lets you connect the printer to an IBM 3270 Type A coax cable computer system operating in the VTAM (CICS/IMS/TSO) or 8100 (DPPX) environment. The printer will emulate an IBM 3287 printer and you can connect it to an IBM 3174/76/99 system controller/multiplexer.

Twinax Interface

This option lets you connect the printer to an IBM twinax cable system with a twinax interface. The printer will emulate an IBM 5256 Model 1 printer and can operate with an IBM System/34, System/36, System/38, or AS/400 host computer.

Finishers

Cutter

The cutter option lets you cut continuous media into individual labels ready for use. You can also order two different trays that will catch the labels as they are cut.

Self-Strip/Full Roll Batch Takeup

The self-strip option allows labels to be peeled from the liner as they print and presented for immediate application to a surface (such as a shipping box). The batch takeup enables you to run the printer in batch mode and is capable of taking up a full roll of media. This option is factory-installed only.

Kanji/Katakana

This option allows the printer to print Japanese characters in two Kanji fonts and three Katakana fonts. This option also provides increased storage capacity.

Memory Expansion

You can install a flash SIMM module into the SIMM socket on the main PCB to hold more fonts or bitmap graphics. You can also install a DRAM SIMM to increase the image buffering capabilities of the printer. You can purchase either module in 8 or 16 MB sizes only.

Bar Code Symbologies Supported

The 4420 and 4440 printers support the following bar code symbologies.

Supported Bar Code Symbologies

Symbology	Description
Codabar	Originally developed in 1972, Codabar is a numeric symbology most commonly used in libraries, blood banks, and air parcel express applications.
Code 2 of 5	Code 2 of 5 is a straightforward numeric symbology developed in the late 1960s. It has been used for warehouse sorting systems, photofinishing envelope identification, and for tracking sequentially numbered airline tickets. All information is contained in the width of the bars; the spaces do not contain information.
Code 11	Code 11 was developed in early 1977 to satisfy requirements for a very high density, discrete numeric bar code. The most extensive application of Code 11 has been for labeling telecommunications equipment.
Code 39	Code 39 is the first alphanumeric symbology ever developed and is the standard non-retail bar code. It is a discrete, self-checking symbology of variable length and is used mostly by the automobile and medical industries.
Code 93	Introduced in 1983, Code 93 was specially designed to complement Code 39. With the correct reading equipment, the two alphanumeric codes may be interchanged throughout a system without making any changes to software.
Code 128	Code 128 was introduced in 1981 as a very high density, alphanumeric symbology. It is a variable length, continuous code that employs multiple element widths.
EAN	The European Article Numbering system (abbreviated as EAN) is a numeric superset of UPC. EAN has both a version that uses 8 digits and a version that uses 13 digits. The version with 13 digits encodes the same number of bars as 12 digit UPC Version A, but the 13th digit is encoded into a parity pattern at the left of the center guard bar.
Interleaved 2 of 5	Interleaved 2 of 5 is a high density, self-checking, continuous numeric symbology, which has mainly been used in the distribution industry. Interleaved 2 of 5 actually encodes two digits, one in the bars and one in the spaces.

Supported Bar Code Symbologies (continued)

Symbology	Description
POSTNET	The Postal Numeric Encoding Technique (POSTNET) uses binary digits, represented as full bars and half bars, to provide a numeric bar code symbology that is easily read and decoded by optical reading systems. POSTNET provides both error detection and correction capabilities.
UPC	Universal Product Code (UPC) is a subset of EAN. It is a fixed length, numeric, continuous symbology employing four element widths. Two common types of UPC are Version A, which encodes 12 digits, and Version E, which encodes 6 digits. UPC has been used in the supermarket industry since 1973. UPC supplemental code is intended for only periodical issue numbers.

2D Symbologies

2D symbologies provide a more efficient way of encoding data than standard bar code symbologies. 2D symbologies use two dimensions to hold data instead of one, allowing much more information to be stored in a smaller amount of space. The printer can print both stacked and matrix 2D symbologies.

2D Stacked Symbologies

2D stacked symbologies consist of short linear segments stacked on top of each other. In addition to being able to condense a large amount of information into the stacked format, PDF417 provides an extensive error detection and correction option. Up to 510 characters can be recovered if they are lost due to an error in scanning or if the label is damaged. 2D stacked symbologies can be scanned with a laser scanner or imaging device that features 2D code scanning capability.

Supported 2D Stacked Symbologies

Symbology	Description
Code 16K	Introduced in 1988, Code 16K is an alphanumeric symbology similar to Code 49 in that it employs multiple rows (from 2 to 16). Each row is fixed length and uses a mirror image of the Code 128 coding patterns.
Code 49	Code 49 is an alphanumeric symbology developed in 1987 as a means of labeling very small objects. A Code 49 bar code contains from two to eight adjacent rows, each separated by a one-module separator bar.

Supported 2D Stacked Symbologies (continued)

Symbology	Description
PDF417	PDF417 is a stacked 2D symbology that provides the ability to scan across rows of code. Each row consists of start/stop characters, row identifiers, and symbol characters (called “codewords”). Each codeword consists of four bars and four spaces and contain the actual data. In addition to being able to condense a large amount of information into the stacked format, PDF417 provides an extensive error detection and correction option. Up to 510 characters can be recovered if they are lost due to an error in scanning or if the label is damaged. PDF417 codes can be scanned with a laser scanner or imaging device that features 2D code scanning capability.
MicroPDF417	MicroPDF417 is a 2D symbology, derived from PDF 417. You use MicroPDF417 for applications needing improved area efficiency but without the requirement for PDF417’s maximum data capacity. MicroPDF417 replaces PDF417’s 17-module-wide start/stop patterns and left/right row indicators with a unique set of 10-module-wide Row Address Patterns, which were designed both to reduce overall symbol width and to enable linear scanning at row heights as low as 2X.

2D Matrix Symbologies

2D matrix symbologies, such as Maxicode, use both the horizontal and vertical axes to encode data even more efficiently than stacked symbologies. 2D matrix codes are created as a matrix of square elements, with each element being either white or black to encode data in a binary code. Extensive error detection and correction codes are appended to 2D matrix symbologies, often automatically.

2D matrix symbologies generally cannot be read with a laser scanner. Instead, they are read by a digital imager that captures the entire symbol at once instead of scanning each component individually. Since the components of 2D matrix symbologies are decoded after the image is captured, they permit very fast data collection.

Supported 2D Matrix Symbologies

Symbology	Description
Data Matrix	Data Matrix is a 2D matrix symbology, which is made up of square modules arranged within a perimeter finder pattern. The finder pattern is a perimeter to the data region and is one module wide. Two adjacent sides are solid dark lines. These lines are used to define physical size, orientation, and symbol distortion.

Supported 2D Matrix Symbologies (continued)

Symbology	Description
Maxicode	<p>Maxicode is a fixed-size symbology that is made up of offset rows of hexagonal elements arranged around a bullseye finder pattern. Each hexagon represents one bit of information and is either black or white depending on the state of the encoded data bit. United Parcel Service (UPS) Research and Development developed Maxicode for the specific purpose of encoding information about a parcel.</p> <p>This symbology only encodes very specific data that is divided into the following fields: a 5-digit zip code, a 4-digit zip code extension, a 3-digit country code, a 3-digit class of service, and a string of uppercase letters, numbers, or limited punctuation marks.</p>
QR Code	<p>QR (Quick Response) Code is a matrix 2D symbology that encodes data into patterns consisting of black and white dots or modules. A three position detection pattern enables omni-directional reading and ultra high-speed reading. QR Code can handle a wide range of data, including numerical, alphabetical, Kanji, Hiragana, Katakana, graphics, and control codes. A built-in error correction function enables the QR Code to repair errors in the code.</p>

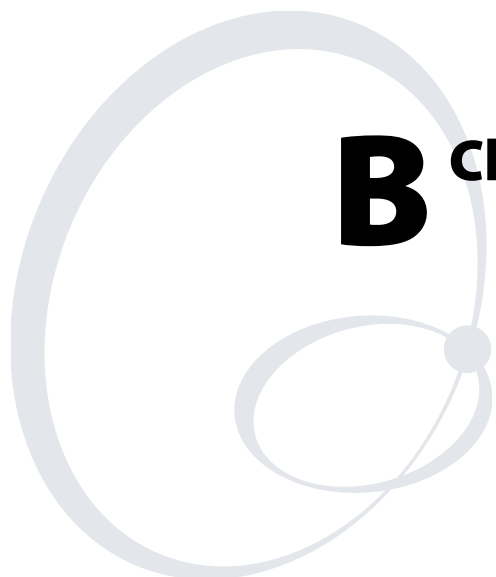

B Character Sets

This chapter contains tables for the character sets that the 4420 and 4440 printers support. To select a character set, use PrintSet, your third-party software application, or the IPL command set. This chapter contains these character sets:

- International character sets
- Extended character sets

International Character Sets

The following tables show which hex codes to download for international characters not available in the U.S. character set. To use the tables, find the hex code for the U.S. character that corresponds with the character in your language.

Advanced Character Table

If you are running the printer in Advanced mode (you are not using 86XX Emulation), use this table to find the right hex codes for the international character sets.

Advanced Mode Hex Codes

	23	24	40	5B	5C	5D	5E	60	7B	7C	7D	7E
U.S. ASCII	#	\$	@	[\]	^	`	{		}	~
U.K. ASCII	£	\$	@	[\]	^	`	{		}	—
Germany	#	\$	§	Ä	Ö	Ü	^	`	ä	ö	ü	ß
France	£	\$	à	°	ç	§	^	`	é	ù	è	..
Norway/Denmark	#	\$	@	Æ	Ø	Å	^	`	æ	ø	å	—
Sweden/Finland	#	Ï	É	Ä	Ö	Å	Ü	é	ä	ö	å	ü
Spain	£	\$	§	ı	Ñ	¿	^	`	°	ñ	ç	~
Switzerland	#	\$	à	°	ç	é	^	ù	ä	ö	ü	è
Italy	£	\$	§	°	ç	é	^	ù	à	ò	è	ì

Emulation Mode Character Table

This table shows the hex codes for the character sets that print if the printer is running under Emulation mode.

Emulation Mode Hex Codes

	23	24	40	5B	5C	5D	5E	60	7B	7C	7D	7E
U.S. ASCII	#	\$	@	[\]	^	`	{		}	~
U.K. ASCII	£	\$	@	[\]	^	`	{		}	~
Germany	#	\$	§	Ä	Ö	Ü	^	`	ä	ö	ü	ß
France	£	\$	à	°	ç	§	^	`	é	ù	è	..
Norway/Denmark	#	\$	@	Æ	Ø	Å	^	`	æ	ø	å	~
Sweden/Finland	#	□	É	Ä	Ö	Å	Ü	é	ä	ö	å	ü
Spain	Pt	\$	@	ı	Ñ	¿	^	`	..	ñ	ç	~
Switzerland	#	\$	à	°	ç	é	^	ù	ä	ö	ü	è
Italy	#	\$	§	°	ç	é	^	ù	à	ò	è	ì

IBM Translation Character Table

If you are running the printer with IBM Translation enabled, use this table to find the right hex codes for the international character sets.

IBM Translation Hex Codes

	21	23	24	40	5B	5C	5D	5E	60	7B	7C	7D	7E
U.S. ASCII		#	\$	@	¢	\	!	¬	`	{		}	~
U.K. ASCII		#	£	@	\$	\	!	¬	`	{		}	_
Germany	!	#	\$	§	Ä	Ö	Ü	^	`	ä	ö	ü	ß
France	!	£	\$	à	°	ç	§	^	`	é	ù	è	¨
Norway/Denmark	!	Æ	Å	Ø	#	\	□	^	`	æ	ø	å	ü
Sweden/Finland	!	Ä	Å	Ö	§	É	□	^	é	ä	ö	å	ü
Spain		Ñ	¿	@	[\]	¬	`	{	ñ	}	¨
Switzerland	!	#	\$	à	°	ç	é	^	ù	ä	ö	ü	è
Italy	!	£	\$	§	°	ç	é	^	ù	à	ò	è	ì

Code Page 850 Character Table

00	☺	☹	♥	♦	♣	♠	●	◻	◯	◼	♂	♀	🎵	🎶	⚙	
10	▶	◀	↕	!!	¶	§	—	↑	↓	→	←	L	↔	▲	▼	
20	!	"	#	\$	%	&	'	()	•	+	,	-	.	/	
30	0	1	2	3	4	5	6	7	8	9	:	;	<	=	>	?
40	@	A	B	C	D	E	F	G	H	I	J	K	L	M	N	O
50	P	Q	R	S	T	U	V	W	X	Y	Z	[\]	^	-
60	`	a	b	c	d	e	f	g	h	i	j	k	l	m	n	o
70	p	q	r	s	t	u	v	w	x	y	z	{		}	~	⏏
80	Ç	ü	é	â	ä	à	å	ç	ê	ë	è	•	"	"	Ä	Å
90	É	æ	Æ	ô	ö	ò	û	ù	ÿ	Ö	Ü	ø	£	Ø	X	f
A0	á	í	ó	ú	ñ	Ñ	ã	õ	¿	®	¬	½	¼	i	«	»
B0	ı	ı	ı	ı	ı	Á	Â	À	©	¶		¶	¶	¢	¥	¬
C0	L	⊥	T	†	—	+	ã	Ã	⌘	Ⓕ	≡	Ⓕ	≡	≡	≡	
D0	'	Ð	Ê	Ë	È	€	Í	Î	Ï	Ɔ	Ɔ	■	■	ı	ı	■
E0	Ó	β	Ô	Ò	õ	Õ	μ	þ	Ɔ	Ú	Û	Ù	ý	Ý	-	'
F0	-	±	=	¾	¶	§	÷	•	◦	••	•	1	3	2	■	FF

44XXU068.eps

Extended Character Sets

Each internal font in the printer has a different character set associated with it as shown in the following tables. The hex codes accompany each character.

Characters in Fonts

- c0 7 x 9 Standard
- c1 7 x 11 OCR
- c2 10 x 14 Standard
- c7 5 x 7 Standard

ML	SH	SH	EX	ET	EQ	PK	EL	BS	HT	LF	UT	FF	CR	SD	SI
00	01	02	03	04	05	06	07	08	09	0A	0B	0C	0D	0E	0F
DL	D1	D2	D3	D4	NK	SN	EB	CN	EM	SB	EC	FS	GS	KS	US
10	11	12	13	14	15	16	17	18	19	1A	1B	1C	1D	1E	1F
	!	"	#	\$	%	&	'	()	*	+	,	-	.	/
20	21	22	23	24	25	26	27	28	29	2A	2B	2C	2D	2E	2F
0	1	2	3	4	5	6	7	8	9	:	;	<	=	>	?
30	31	32	33	34	35	36	37	38	39	3A	3B	3C	3D	3E	3F
@	A	B	C	D	E	F	G	H	I	J	K	L	M	N	O
40	41	42	43	44	45	46	47	48	49	4A	4B	4C	4D	4E	4F
P	Q	R	S	T	U	V	W	X	Y	Z	[\]	^	_
50	51	52	53	54	55	56	57	58	59	5A	5B	5C	5D	5E	5F
'	a	b	c	d	e	f	g	h	i	j	k	l	m	n	o
60	61	62	63	64	65	66	67	68	69	6A	6B	6C	6D	6E	6F
p	q	r	s	t	u	v	w	x	y	z	{		}	~	█
70	71	72	73	74	75	76	77	78	79	7A	7B	7C	7D	7E	7F
R	à	■	□	△	▽										
80	81	82	83	84	85	86	87	88	89	8A	8B	8C	8D	8E	8F
90	91	92	93	94	95	96	97	98	99	9A	9B	9C	9D	9E	9F
	·	·	·	·	·	·	·	·	·	·	·	·	·	·	·
A0	A1	A2	A3	A4	A5	A6	A7	A8	A9	AA	AB	AC	AD	AE	AF
•															·
B0	B1	B2	B3	B4	B5	B6	B7	B8	B9	BA	BB	BC	BD	BE	BF
				·	·	·			·						
C0	C1	C2	C3	C4	C5	C6	C7	C8	C9	CA	CB	CC	CD	CE	CF
	·					·		·				·			·
D0	D1	D2	D3	D4	D5	D6	D7	D8	D9	DA	DB	DC	DD	DE	DF
à				·	·	·	·	·	·	·	·	·			
E0	E1	E2	E3	E4	E5	E6	E7	E8	E9	EA	EB	EC	ED	EE	EF
	·	·			·	·	·	·	·	·	·	·			
F0	F1	F2	F3	F4	F5	F6	F7	F8	F9	FA	FB	FC	FD	FE	FF

44XXU069.eps

Characters in Fonts

- c20 8 point
- c21 12 point
- c22 20 point
- c25, c26, c28 outline fonts
- c30-c41 monospace fonts (6 point to 36 point)

00	01	02	03	04	05	06	07	08	09	0A	0B	0C	0D	0E	0F
10	11	12	13	14	15	16	17	18	19	1A	1B	1C	1D	1E	1F
20	!	"	#	\$	%	&	'	()	*	+	,	-	.	/
30	0	1	2	3	4	5	6	7	8	9	:	;	<	=	>
40	@	A	B	C	D	E	F	G	H	I	J	K	L	M	N
50	P	Q	R	S	T	U	V	W	X	Y	Z	[\]	^
60	`	a	b	c	d	e	f	g	h	i	j	k	l	m	n
70	p	q	r	s	t	u	v	w	x	y	z	{		}	~
80	€														
90															
A0	ı	ç	£	¤	¥	¦	§	¨	©	ª	«	¬	-	®	¯
B0	°	±	²	³	´	µ	¶	·	¸	¹	º	»	¼	½	¾
C0	À	Á	Â	Ã	Ä	Å	Æ	Ç	È	É	Ê	Ë	Ì	Í	Î
D0	Ð	Ñ	Ò	Ó	Ô	Õ	Ö	×	Ø	Ù	Ú	Û	Ü	Ý	Þ
E0	à	á	â	ã	ä	å	æ	ç	è	é	ê	ë	ì	í	î
F0	ð	ñ	ò	ó	ô	õ	ö	÷	ø	ù	ú	û	ü	ý	þ

44XXU070.eps



Note: You cannot print these characters as 4 x 4 inch graphics because there is white space surrounding the characters that prevents the image from reaching the maximum graphic size.

Characters in Fonts

c23 OCR A

00	01	02	03	04	05	06	07	08	09	0A	0B	0C	0D	0E	0F
10	11	12	13	14	15	16	17	—	19	1A	1B	1C	1D	1E	1F
	!	"	#	\$	%	&	'	()	*	+	,	-	.	/
20	21	22	23	24	25	26	27	28	29	2A	2B	2C	2D	2E	2F
0	1	2	3	4	5	6	7	8	9	:	;	<	=	>	?
30	31	32	33	34	35	36	37	38	39	3A	3B	3C	3D	3E	3F
@	A	B	C	D	E	F	G	H	I	J	K	L	M	N	O
40	41	42	43	44	45	46	47	48	49	4A	4B	4C	4D	4E	4F
P	Q	R	S	T	U	V	W	X	Y	Z	[\]	^	_
50	51	52	53	54	55	56	57	58	59	5A	5B	5C	5D	5E	5F
h	a	b	c	d	e	f	g	h	i	j	k	l	m	n	o
60	61	62	63	64	65	66	67	68	69	6A	6B	6C	6D	6E	6F
p	q	r	s	t	u	v	w	x	y	z	{		}	~	■
70	71	72	73	74	75	76	77	78	79	7A	7B	7C	7D	7E	7F
80	81	82	83	84	85	86	87	88	89	8A	8B	8C	8D	8E	8F
90	91	92	93	94	95	96	97	98	99	9A	9B	9C	9D	9E	9F
			£		¥										
A0	A1	A2	A3	A4	A5	A6	A7	A8	A9	AA	AB	AC	AD	AE	AF
B0	B1	B2	B3	B4	B5	B6	B7	B8	B9	BA	BB	BC	BD	BE	BF
C0				Ä	Å	Æ									
C0	C1	C2	C3	C4	C5	C6	C7	C8	C9	CA	CB	CC	CD	CE	CF
D0	Ñ					ö		ø				Ü			
D0	D1	D2	D3	D4	D5	D6	D7	D8	D9	DA	DB	DC	DD	DE	DF
E0	E1	E2	E3	E4	E5	E6	E7	E8	E9	EA	EB	EC	ED	EE	EF
F0	F1	F2	F3	F4	F5	F6	F7	F8	F9	FA	FB	FC	FD	FE	FF

44XXU071.eps

Characters in Fonts

c24 OCR B Size 2

00	01	02	03	04	05	06	07	08	09	0A	0B	0C	0D	0E	0F	
10	11	12	13	14	15	16	17	18	19	1A	1B	1C	1D	1E	1F	
20	!	"	#	\$	%	&	'	()	*	+	,	-	.	/	
30	0	1	2	3	4	5	6	7	8	9	:	;	<	=	>	?
40	@	A	B	C	D	E	F	G	H	I	J	K	L	M	N	O
50	P	Q	R	S	T	U	V	W	X	Y	Z	[\]	^	_
60	`	a	b	c	d	e	f	g	h	i	j	k	l	m	n	o
70	p	q	r	s	t	u	v	w	x	y	z	{		}	~	■
80																
90																
A0			£	¤	¥	¦	§	¨								
B0				'				'								
C0				À	Á	Æ										
D0	Ñ				Ö		Ø					Ü				ß
E0				ä	å	æ										
F0	ñ				ö		ø					ü				

44XXU072.eps

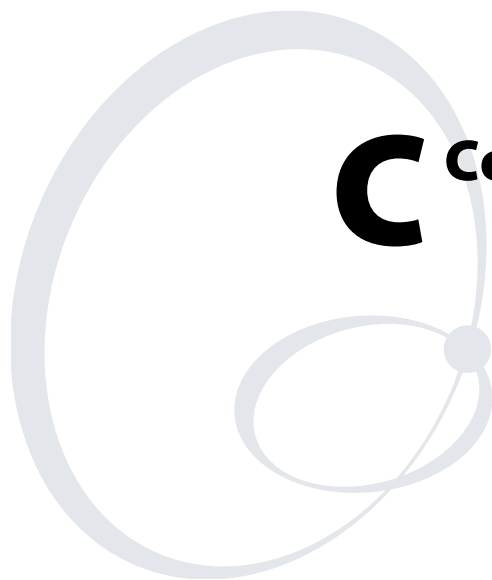

C Communications Reference

This chapter provides communications reference information. This chapter covers these topics:

- Communications protocols
- Communications interfaces
- Serial port communications

Communications Protocols

Communications protocols are important because they determine the transmission standards for communications between the printer and the host. The printer and the host must use the same protocol and parameters to communicate properly. The printer supports the flow control and block transfer protocols described in the next sections. All of these protocols are point-to-point except Multi-Drop. Application programs and/or ROM BIOS determine which protocols your computer can support. For more detailed information, refer to the *Data Communications Reference Manual* (P/N 044737).

Intermec Standard Protocol

Intermec Standard protocol is a proprietary block transfer/status response protocol. For each block sent, the host must wait for the appropriate response before sending the next block (<DC1>). Except for single character status commands (<ENQ> and <VT>), Standard protocol transmits characters in message blocks beginning with the start of text (<STX>) character and ending with the end of text (<ETX>) character. Message blocks can be up to 255 characters, including the start of text and end of text characters. The printer auto-discriminates between Standard, Polling Mode D, and Multi-Drop protocols.

The printer returns its highest priority status when it receives a valid block (<STX> data <ETX>) or when it receives the status request command <ENQ>. When the printer receives the status dump command (<VT>), the printer returns all active status. The printer status response time ranges from 30 to 100 ms depending on the complexity of the received message block. In the case of a transmission error, the printer responds with a <NAK> and discards the entire message block.

This table shows printer status conditions in descending order of priority:

Intermec Standard Protocol Printer Status Conditions

Printer Status	Character
Buffer already full	GS
Ribbon fault	US
No label stock	EM
Buffer now full	DC3
Printhead hot	SI
Offline (paused)	DC3
Label at strip pin	FS
Skipping	DC1
Printing	DC1
Ready/Online	DC1



Note: Do not confuse the Buffer now full <DC3> status with the XON/XOFF characters <DC1> and <DC3>.

When the printer returns Buffer now full (<DC3>) status, it accepts the currently received message block. At this time, the printer can accept short messages to allow parsing of immediate commands such as Reset (<DLE>) or Cancel batch printing (). However, if the printer responds with a <GS> to any message block, the buffer is already full and it discards the entire message block.

XON/XOFF Protocol (Software and Hardware Flow Control)

XON/XOFF protocol uses the ASCII characters <DC1> (XON) and <DC3> (XOFF) to start and stop the flow of data from the host to the printer. The printer does not restrict the message length for XON/XOFF protocol. That is, the printer processes information as it is being downloaded and stops when there is no more information.

<STX> and <ETX> are optional characters. However, if you send an STX, the printer ignores all other characters until you send an ETX.

Intermec provides two versions of the XON/XOFF protocol. The Intermec version of XON/XOFF has the printer respond to each message with its current status. The other version conforms to generally accepted industry standards, which include no end-of-message response being sent to the host other than XOFF. In addition, a DC3 is sent to the host if the printer is offline or if media fault occurs. An XON is sent on power up.

Since the printer uses DC1 and DC3 for data flow control, the printer status characters are different from those of the Standard Protocol.

XON/XOFF Protocol Printer Status Conditions

Printer Status	Character
Buffer already full	GS
Ribbon fault	US
No label stock	EM
Printhead hot	SI
Buffer now full	DC4
Label at strip pin	FS
Label skipping	DC2
Printing	DC2
Ready	DC2

If the host ignores the printer sending an XOFF, the printer resends an XOFF after receiving every 15 characters from the host. In the case of transmission error, the printer discards the characters with the error and keeps the rest of the message block.

Polling Mode D

Polling Mode D is a block transfer protocol that transmits data in blocks of up to 255 characters, including protocol overhead. For Polling Mode D, the host/concentrator is responsible for asking the printer for data it might have (polling) and requesting to send data to the printer (selecting). LRC characters frame the blocks for additional data integrity. Use Polling Mode D for point-to-point networks that connect the printer to an Intermec port concentrator (RS-232 or RS-422 are acceptable).

This protocol is the default setting for the 4420 and 4440 printer. Return the protocol setting to Polling Mode D by setting the printer DIP switches to the factory default settings (9600, E, 7, 1) or by sending down the Test and Service mode command D.

Multi-Drop Protocol

Use Multi-Drop protocol to connect up to 32 devices to an Intermec controller on a four-wire RS-485 (two twisted pair). This protocol is similar to Polling Mode D except each device has a unique address (POL and SEL character). You must use an RS-485, which is automatically enabled when you enable Multi-Drop. Be sure to specify a unique address for the printer and verify that the baud rate is between 2400 and 19200.

Hardware Protocol

The printer uses Ready/Busy and DTR (data terminal ready) of the RS-232C interface to indicate the printer's status. You can configure Ready/Busy and DTR independent of each other and independent of the software protocol you select for the serial port. You can set each pin to one of these three settings: default, high, and Ready/Busy.

When you set the pin to high, the printer will be ready to accept data anytime.

When you set the pin to Ready/Busy, the pin is high when the printer status is ready. The pin is held low when the printer is in one of these conditions:

- Offline
- Buffer full
- No label stock
- Ribbon fault
- Label at strip pin

If you set the printer to XON/XOFF protocol, the XON and XOFF characters will not be transmitted back to the host.

When you set the pin to default, it uses flow control if the serial port is set for XON/XOFF protocol. If you are using Intermec Standard protocol, the printer uses Ready/Busy.

User-Defined Protocol

The 4420 and 4440 printers provide the capability to change protocol characters. However, you cannot define your own protocol. You can substitute characters to use as protocol characters, but the rules for the chosen protocol do not change. The printer does not use any protocol characters that you replace with the NUL character. One table of protocol characters exists. You may redefine these characters to create a table that all of the protocols can use. One possibility for you to redefine protocol characters may be the replacement of control characters with printable characters.



Note: Please use caution when replacing control characters with printable characters. One control character can be replaced with only one printable character.

The next table lists the protocol characters that you can redefine and the protocols they affect.

Protocols Affected by Redefining Characters

Character	STD	POL Mode D	Multi-Drop	XON/XOFF
SELECT IN		X	X	
POLL IN		X	X	
RES IN		X	X	
REQ IN		X	X	
SOM IN	X	X	X	X
EOM IN	X	X	X	X
AFF IN		X	X	
NEG IN		X	X	
DLE IN	X	X	X	X
XON IN				X
XOFF IN				X
SELECT OUT			X	
POLL OUT			X	
RES OUT		X	X	
REQ OUT		X	X	
SOM OUT		X	X	
EOM OUT		X	X	
AFF OUT		X	X	
NEG OUT	X	X	X	
DLE OUT	X	X	X	X

Protocols Affected by Redefining Characters (continued)

Character	STD	POL Mode D	Multi-Drop	XON/XOFF
XON OUT				X
XOFF OUT		X	X	X
PROTO-CMD 1	X			X
PROTO-CMD 2	X			X
TIMEOUT ON EOM		X	X	

Host Requirements

The 4420 and 4440 printers have the following hardware and software requirements:

- The host computer must use the American Standard Code for Information Exchange (ASCII) for data communications.
- A serial port or a parallel port must be available on the host if you are connecting directly to the printer.
- The host must support at least one of the following data communications interfaces: RS-232, RS-422, RS-485 (115K), or IEEE compliant 1284 bi-directional parallel.

For information on configuring the host computer, port concentrator, or network controller, see the reference manual for the controlling device.

Communications Boundaries

The information below applies to all protocols that the printer supports.

Maximum Capacity Communications Boundaries

Parameter	Maximum Capacity
Message delay	9999 milliseconds
Character delay	9999 milliseconds
Message block size	255 characters (including STX and ETX characters) Unlimited block size for XON/XOFF
Device address number (Multi-Drop only)	A to Z, 0 to 5

Communications Interfaces

The 4420 and 4440 printers come standard with both a serial port and a bi-directional parallel port.

The parallel port conforms to the IEEE 1284 standard and it supports Initialization, Compatibility Mode, Negotiation, Nibble, and Byte Mode for reverse data transfer.

The serial port supports serial communications with the following interfaces:

- RS-232
- RS-422
- RS-485

The following sections describe these interfaces. See the *Data Communications Reference Manual* (P/N 044737) for more detailed information.

RS-232 Serial Interface

Use the RS-232 serial interface in all asynchronous point-to-point full- or half-duplex direct data communications or modem control. The printer cable must have the pin assignments for an RS-232 serial interface shown in the next table.

RS-422 Serial Interface

Use the RS-422 interface in long line point-to-point direct connect installations. The printer cable must have the pin assignments for an RS-422 serial interface shown in the next table.

RS-485 Serial Interface

Use the RS-485 serial interface for Multi-Drop installations only. The printer cable must have the pin assignments for an RS-485 serial interface shown in the next table.

RS-232, RS-422, and RS-485 Serial Interface Pin Assignments

Interface	Pin	Name	Operation
RS-232/422/485	1	Chassis Ground (GND)	Connect to pin 1, chassis ground, of connected device.
RS-232	2	Transmit Data (TD)	Output: Connect to receive data pin of connected device.
RS-232	3	Receive Data (RD)	Input: Connect to transmit data pin of connected device.
RS-232/422/485	4	Request to Send (RTS)	Output: When you use a modem, connect to modem RTS pin. The connection sets RTS to true before transmission. The printer sets RTS to false after transmission.
RS-232/422/485	5	Clear to Send (CTS)	Input: When you use a modem, connect to modem CTS pin. Modem must set CTS true before the printer transmits data. If not connected, CTS sets itself true.

RS-232, RS-422, and RS-485 Serial Interface Pin Assignments (continued)

Interface	Pin	Name	Operation
RS-232/422/485	7	Signal Ground (SG)	To enable communications, connect to signal ground of connected device. Completes circuit for all RS-232 signals.
RS-232/422/485	11	Printer Status (PS)	Output: When not using software flow control (XON/XOFF), connect to input of connected device (for example, CTS). Indicates printer mechanical status and status of printer input buffer.
RS-422/485	13	Input B	Input: Serial differential data to the printer.
RS-422/485	14	Output A	Output: Serial differential data from the printer.
RS-422/485	16	Input A	Input: Serial differential data to the printer.
RS-422/485	19	Output B	Output: Serial differential data from the printer.
RS-232/422/485	20	Data Terminal Ready (DTR)	Output: When you use a modem, connect to modem DTR pin. When using Intermecc Standard protocol, this pin indicates that the printer is switched on. When using XON/XOFF or hardware flow control, this pin indicates the printer mechanical status and the status of the printer input buffer.

Printer Serial Port

The rear panel of the printer contains the serial port connector. It is a 25-pin D-style subminiature receptacle. The port is wired as a data terminal equipment (DTE) device.

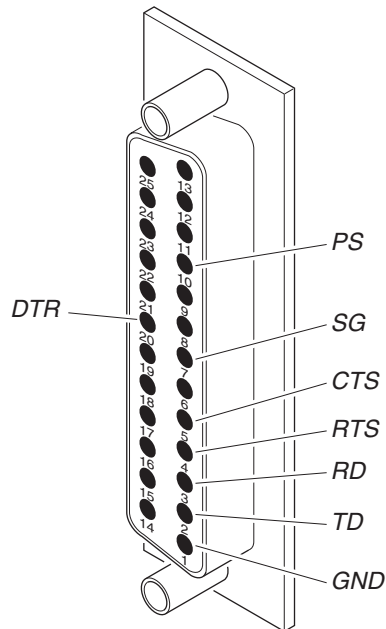

44XXU073.eps

Serial port pin assignments: This illustration shows the serial port pin assignments.

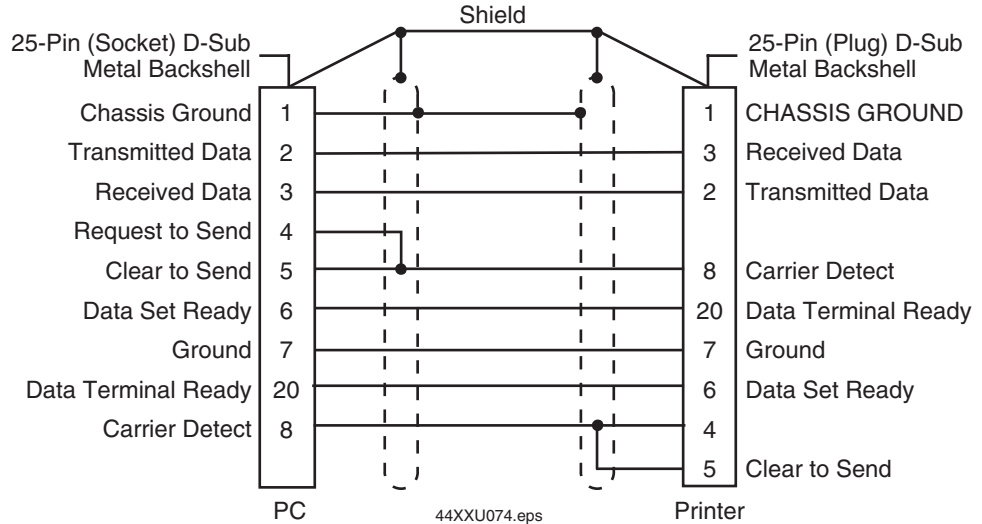

25-Pin PC Connector RS-232 null modem cable: This illustration shows the pin assignments for the RS-232 null modem cable for the 25-pin PC connector (P/N 048668).



Note: The metal backshell is connected directly to the shield to achieve electrostatic discharge (ESD) immunity.

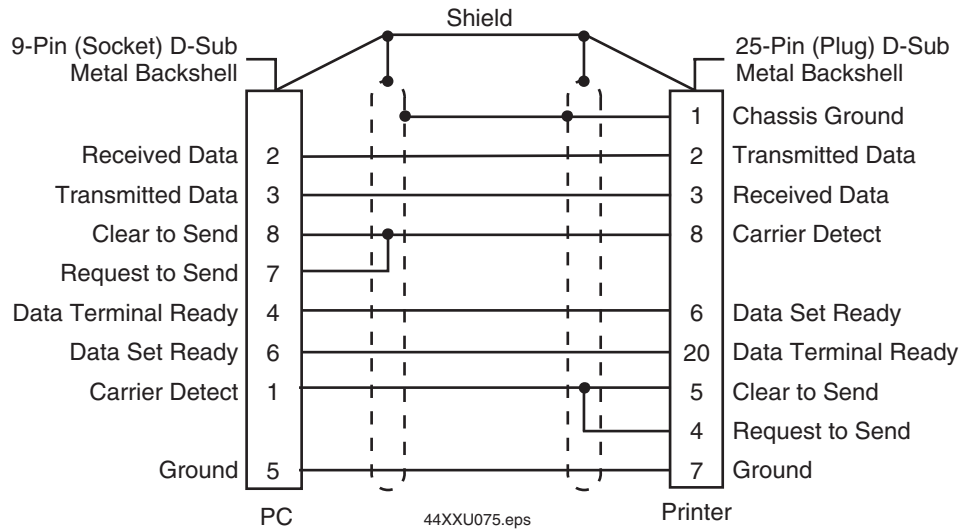

9-Pin PC Connector: This illustration shows the pin assignments for the RS-232 null modem cable for the 9-pin PC connector (P/N 048693).



Note: The metal backshell is connected directly to the shield to achieve electrostatic discharge (ESD) immunity.

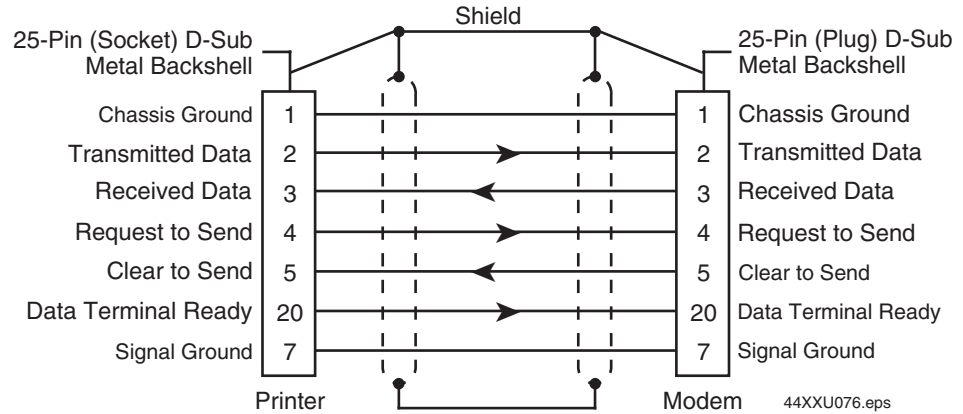

Straight Through DTE to DCE Cable: This illustration shows the pin assignments for the straight through DTE to DCE cable used with a modem (P/N 043237S). If you find that you are losing data, you may need to isolate the chassis ground from one of the two devices by connecting it to the shield.



Note: The metal backshell is connected directly to the shield to achieve electrostatic discharge (ESD) immunity.

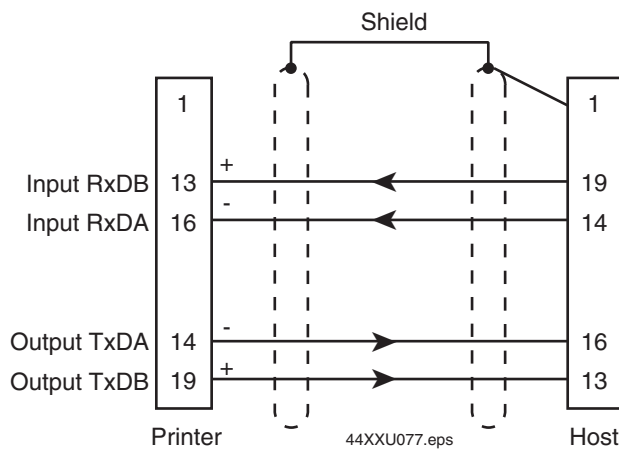

RS-422 serial interface: This illustration shows the pin assignments for the RS-422 serial interface. The host in this case includes Intermec products that support RS-422. Non-Intermec controllers may have different pin assignments.



Note: Connect pin 1 to shield at one end only.



G Glossary

backing

Silicon release liner on media to which labels are attached until ready for use.

batch takeup

A device that rewinds media; useful for printing batches of labels.

BEL

A command character that instructs the printer to return an error status code.

character sets

The letters, numerals, and symbols that support particular languages (such as French, or U.S. ASCII) or automatic identification technology (such as Code 39 or Codabar).

cloning

A procedure that copies the RAM contents (configuration, formats, fonts, pages, and graphics) from the memory of one printer to the memory of another.

data file

The collection of data and printer commands that, when sent to the printer, is merged with a format file to print a label.

Data Line Print mode

A mode of operation in which the printer prints each command (accompanied by its ASCII code in hexadecimal format) that it receives from the host.

density

The number of data characters that can be represented in a linear unit of measure. Often expressed in characters per inch.

direct thermal

A method of thermal printing in which images are printed when heat from the thermal printhead produces a black mark on the media.

drag

A method of bar code printing in which all the bars are printed at once, in parallel. The bar code appears across the width of the label.

EAN

European Article Numbering; now also called IAN (International Article Numbering). International standard bar code for retail food packages corresponding to the Universal Product Code (UPC) in the United States.

Emulation mode

An operating mode in which the printer has the operating characteristics of another printer. For example, the 3440 can operate in 8636/46 Emulation, which emulates an Intermec 8636 or 8646 printer.

field

A graphic element that is the basic unit of a format. The four basic types of fields are bar code, graphic, line, and text.

fixed data field

Bar code and text fields that never vary from one label to the next; the data in a fixed field is a permanent part of the format.

fixed format

A format in which the data never varies from one label to the next, such as a return address label. A fixed format needs no additional data to print a label.

font

A character set of a given type size and style. See also character set.

font file

See soft font.

format file

A collection of printer commands and data that determines the arrangement of fields on a label.

graphic

A bitmap picture downloaded to the printer by the host before printing.

HIBC

Health Industry Bar Code standard. A modified version of Code 39 that has 43 characters, utilizes the Modulus 43 check character, and reserves some character combinations for special usage.

human-readable

A character, number, or symbol printed in a font that a human can read; as opposed to bar code symbology, which only a machine can read.

image bands

A portion of an image in the shape of a strip of the image. A certain number of image bands are stored in memory before printing begins. This method allows printing and imaging to take place simultaneously.

imaging

The process of generating a picture of the label in printer memory.

increment/decrement field

Bar code or text fields the printer automatically changes from one label to the next. For example, a batch of labels with serial number text or bar code fields, that change from 001, to 002, to 003, and so on.

index

To move from the start of the label to the start of print. With continuous media, to advance the media over the “label gap” to the “edge” of the next label.

interpretive field

A text field that describes the data in the associated bar code field.

ips

Inches per second. A measurement of print speed that measures the number of inches of media that is printed each second.

ISO

International Organization for Standardization. An internationally accepted 7-bit character code. (The U.S. version is ASCII.)

label

The part of the media on which data is printed.

label format

The design of a bar code label; the arrangement of the text, lines, and bar codes on a label.

label gap

The space between labels on die-cut label stock.

margin

The distance between the edge of a label and where the printing starts on that label. See also top of form.

media

The label stock on which the printer prints labels. Media can be made of plain paper, polyester, thermally reactive paper, or other materials with adhesive backing and ribbon.

mnemonic code

An acronym or abbreviation for a computer instruction, routine, or format. For example, <STX> represents the start of text.

Multi-Drop protocol

A protocol capable of controlling communications between a single controller and multiple devices.

nibblized

A software term that refers to grouping bits into sets of four, called nibbles. Usually bits are grouped into sets of eight, which are called bytes.

OCR font

A font that is recognized by optical character recognition.

offline

The state in which the printer is not able to carry out two-way communication with the host.

online

The state in which the printer is able to carry out two-way communication with the host.

page

A group of labels that are always printed together. When labels on a page share the same data, it reduces the number of commands that must be sent to the printer.

parallel

A communication scheme in which the bits of a byte are transferred simultaneously over a multistrand cable.

picket

A method of bar code printing in which the bars in the bar code print one at a time, in a series. The bar code appears along the length of the label.

pitch

(1) The number of characters printed in one horizontal inch determined by the increment by which the printer platen moves. (2) Rotation of a bar code symbol about an axis parallel to the direction of the bars.

point size

A unit of measure for font height; 72 points equals 1 inch as measured from slightly above the top of the uppercase letters to slightly below the bottom of the lowercase descenders.

Polling Mode D protocol

Polling Mode D is a protocol that allows devices and controllers to exchange data in an “ask and receive” format. Use Polling Mode D to connect multiple devices to a single multiport controller.

print speed

Measured in inches per second (ips), the rate at which media travels past the printhead.

printhead

The mechanism inside the printer that prints. The printhead for the 4420 printer consists of 896 thermal elements. The printhead for the 4440 printer consists of 1792 thermal elements.

printhead elements

The parts of the printhead that print by placing a mark on the label when heated. Each element on the 4420 printer is 0.005 inches square in area. Each element on the 4440 printer is 0.0025 inches square in area. Each element is switched on and off separately in order to react with the media or thermal transfer ribbon to create a mark on the label.

ready

The state in which the printer is able to print; the normal operating state of the printer.

Ready/Busy line

Pin 11/20 of the rear panel connector. Indicates whether the printer is ready or not ready (busy).

RS-232

Widely recognized protocol standard for serial binary data interchange. The standard covers the physical, electrical, and functional characteristics of the interface.

RS-422

Standard for the voltage and impedance levels for serial data transmission on balanced lines. Similar to RS-232, but handles larger distances and faster communication.

RS-485

Standard for allowing multiple devices to share a common set of serial data communication lines. The signaling is very similar to RS-422. The maximum number of devices allowed is 32.

scan

To read a bar code with a device known as a scanner that converts optical information into electrical signals.

scannable

A symbol that can be successfully scanned and correctly decoded.

selective transfer

A procedure that copies selected formats, fonts, graphics, or pages stored in the memory of one printer to the memory of another.

self-strip

An optional factory-installed device for the printer that presents each label after it is printed, with the backing removed so it may be applied immediately.

sensitivity

The responsiveness of thermal media, or of thermal transfer ribbon, to heat; it is determined by the time required for a unit measure of heat to affect the media or ribbon.

serial

A communication scheme in which the bits of a byte are transferred one at a time. Often, serial transmission is used to link host computers to terminals and PCs to printers,

skip

To move the paper to the next label.

soft font

A file stored in the printer to provide the ability to print text using fonts that are not resident in the printer.

Standard protocol

A communications protocol capable of controlling communications between two devices connected by a single data communication line.

symbology

A scheme for encoding data as bar code. Code 39, Interleaved 2 of 5, and Codabar are examples of different symbologies.

thermal transfer

A method of printing by which heat from the printhead melts ink from the ribbon onto media. The ink adheres to the media as it cools and the ribbon is removed.

top of form

The point where printing can start on a label. The top of form is separated from the edge of the label by the margin.

UPC

Universal Product Code. A numeric, 12-digit bar code symbology used extensively in retail, particularly the grocery industry.

UDC

User Defined Character. See graphic.

UDF

User Defined Font. See soft font.

variable data field

Bar code and text fields that change from one label to the next.

XON/XOFF

A protocol that stops the host from sending data when the printer buffer fills up and starts it again when the buffer empties.



Index

Numbers

- 2D symbologies, 82
 - Code 16K, 82
 - Code 49, 82
 - Data Matrix, 83
 - Maxicode, 84
 - MicroPDF417, 83
 - PDF417, 83
 - QR Code, 84

A

- AC power receptacle, 6
- adjustments
 - bias adjust screw, 48
 - darkness adjust control, 49
 - label gap sensor, 55
 - label mark sensor, 56
 - label rest point, 68
 - X forms adjust, 72
 - Y forms adjust, 72
- Advanced mode, international character sets, 86, 87
- Alert LED
 - described, 4
 - troubleshooting, 41
- AS400, connecting to the printer, 24

B

- backing, definition, 104
- bands, image, 58
- bar code symbologies
 - Codabar, 81
 - Code 11, 81
 - Code 128, 81
 - Code 2 of 5, 81
 - Code 39, 81
 - Code 93, 81
 - EAN, 81
 - Interleaved 2 of 5, 81
 - list of, 81
 - POSTNET, 82
 - UPC, 82
- batch takeup
 - definition, 104
 - described, 80
- BEL, definition, 104
- bias adjust screw
 - adjusting, 48
 - using for optimal print quality, 48
- bi-directional parallel port, 98
- boundaries, communication, 98

C

- cables
 - considerations in noisy electrical environments, 25
 - null-modem schematics, 101
 - RS-232 schematics, 101
 - RS-422 schematic, 102

- changing core-locking brackets, 11
- character sets
 - Advanced mode, 86, 87
 - Code Page 850, 88
 - definition, 104
 - extended, 89
 - international, 86
 - list of, 76
- cleaning
 - label sensors, 37
 - media guides, 36
 - media path, 36
 - printer, 31
 - printer covers, 34
 - printhead, 32
 - rollers, 35
 - tear bar, 35
- cloning, definition, 104
- coax interface option, 80
- Codabar, 81
- Code 11, 81
- Code 128, 81
- Code 16K, 82
- Code 2 of 5, 81
- Code 39, 81
- Code 49, 82
- Code 93, 81
- Code Page 850, character table, 88
- communicating with the printer, 27
 - using PrintSet, 27
 - using third-party software, 27
- communications
 - boundaries, 98
 - configuring the serial port, 25
 - problems, 44
 - protocols, 94
 - hardware, 96
 - Multi-Drop, 96
 - Polling Mode D, 96
 - Standard, 94
 - user-defined, 97
 - XON/XOFF, 95
- reference
 - communication boundaries, 98
 - communication protocols, 94
 - host requirements, 98
 - See also* protocols.
 - testing by printing a test label, 28
 - troubleshooting, 45, 64
- communications interfaces, 79, 99
- configuration commands
 - changing from Test and Service mode, 66
 - Emulation mode, 66
 - label rest point, 66
 - X forms adjust, 66
 - Y forms adjust, 66
 - DIP switch settings, 66

- configuration test labels
 - hardware, 14
 - software, 16
 - troubleshooting, 41
 - configuration, printing test label, 64
 - configuring the serial port, 25
 - connecting
 - printer to a mainframe, 24
 - printer to a network, 23
 - printer to a PC
 - using the parallel port, 23
 - using the serial port, 23
 - printer to an AS400, 24
 - printer to power source, 6
 - printer to system, 22
 - using the parallel port, 22
 - using the serial port, 22
 - core-locking brackets, changing, 11
 - cutter option, 80
- D**
- darkness adjust control
 - setting, 49
 - using for optimal print quality, 49
 - data file, definition, 104
 - Data Line Print, 64
 - entering, 64
 - using to test the operation of the printer, 64
 - using to troubleshoot printer, 64
 - Data Line Print, definition, 104
 - data loss
 - checking for communications problems, 45
 - preventing, 44
 - Data Matrix, 83
 - default settings, *See* factory default settings
 - density, definition, 104
 - dimensions, printer, 76
 - DIP switch settings
 - chart, 26
 - configuration commands, 66
 - descriptions, 25
 - for dot increments, 67
 - Test and Service mode, 63
 - direct thermal, definition, 104
 - dot increments, setting the number of, 67
 - downloading, definition, 27
 - drag, definition, 104
- E**
- EAN
 - definition, 105
 - described, 81
 - EasyLAN 10i interface option, 79
 - EasyLAN 10i2 adapter accessory, 80
 - EasyLAN Wireless interface option, 80
 - electrical requirements, 76
 - Empty/Pause LED, 4
 - Emulation mode, 69
 - definition, 105
 - international character sets, 86
 - setting with DIP switches, 69
 - entering, Test and Service mode, 62
 - environment specifications, 76
 - Ethernet interface option, *See* EasyLAN 10i interface option
 - exiting, Test and Service mode, 62
 - extended character sets, 89
- F**
- factory default settings, 78
 - fanfold media, loading, 9
 - faults, media or system, 4
 - Feed/Pause button, using, 5
 - field, definition, 105
 - fixed data field, definition, 105
 - fixed format, definition, 105
 - flash SIMM, additional storage memory, 57
 - font
 - copying to another printer, *See* selective transfer
 - definition, 105
 - extended character sets, 89
 - file, definition, 105
 - specifications, 76
 - tables, extended character sets, 89
 - format
 - conventions, used in this manual, xi
 - copying to another printer, *See* selective transfer
 - file, definition, 105
 - positioning with DIP switches, 71
 - forms adjust
 - positioning the label format, 71
 - setting from DIP switches, 71
 - front panel
 - LEDs, 3
 - understanding, 3
- G, H**
- graphic
 - copying to another printer, *See* selective transfer
 - definition, 105
 - specifications, 76
 - hardware configuration test label, printing, 14
 - hardware protocol, 96
 - HIBC, definition, 105
 - host requirements, communications, 98
 - human-readable, definition, 105
- I**
- image bands
 - definition, 106
 - description, 58
 - function, 58
 - optimizing with print speed, 59
 - imaging, definition, 106
 - increasing printer throughput, 58
 - increment/decrement field, definition, 106

Index

- index, definition, 106
- indicator LEDs, front panel, 3
- inspecting the printer, 30
- interfaces
 - coax, 80
 - communications, 79, 99
 - EasyLAN 10i, 79
 - EasyLAN 10i2 adapter accessory, 80
 - EasyLAN Wireless, 80
 - RS-232, 99
 - RS-422, 99
 - RS-485, 99
 - twinax, 80
- Interleaved 2 of 5, 81
- Intermec Standard protocol, 94
- international character sets, 86
- interpretive field, definition, 106
- ips, definition, 106
- ISO, definition, 106
- K, L**
- Kanji/Katakana option, 81
- label
 - definition, 106
 - detecting the start, 54
 - format
 - definition, 106
 - position, adjusting with TOF switch, 51
 - positioning along the length of label, 72
 - positioning parallel along width of label, 72
 - gap
 - definition, 106
 - sensor, adjusting, 54
 - mark sensor, adjusting, 56
 - printing a test, 28
 - rest point, adjusting, 68
 - sensors, cleaning, 37
- languages, international character sets, 86
- LEDs
 - Alert, 4
 - Empty/Pause, 4
 - front panel, 3
 - media or system faults, 4
 - over-temperature condition, 4
 - Power/Data, 4
 - understanding, 3
 - using to troubleshoot the printer, 4
- loading
 - fanfold media, 9
 - roll media, 8
 - thermal transfer ribbon, 11
- loading thermal transfer ribbon, 12
- M**
- mainframe, connecting to the printer, 24
- maintenance, 30
 - location of parts to be maintained, 31
 - schedule, 30
 - tools for cleaning, 31
- manual
 - format conventions, xi
 - terminology, xi
- manuals, reference, xi
- margin, definition, 106
- matrix symbologies, *See* 2D symbologies
- Maxicode, 84
- media
 - definition, 107
 - direct thermal media settings table, 18
 - fault, troubleshooting, 41, 43
 - guides, cleaning, 36
 - loading into printer, 7
 - media sensitivity number
 - description, 15
 - setting for Intermec media and ribbon, 16
 - setting for other media and ribbon, 17
 - setting with PrintSet, 17
 - or system faults, 4
 - path, cleaning, 36
 - specifications, 77
 - thermal transfer settings table, 18
- memory
 - additional storage, flash SIMM, 57
 - expansion option, 81
 - increasing amount available, 57, 65
 - limitations, 57
 - reset, using, 65
 - returning printer to default settings, 65
 - specifications, 77
 - usage
 - limitations, 57
 - problems, 57
 - using efficiently, 57
- MicroPDF417, 83
- mnemonic code, definition, 107
- modem, DTE to DCE cable schematics, 102
- MSN, *See* media sensitivity number
- Multi-Drop protocol
 - definition, 107
 - described, 96
- N, O**
- network, connecting to the printer, 23
- nibblized, definition, 107
- OCR font, definition, 107
- offline, definition, 107
- on/off switch, 6
- online, definition, 107
- opening the printer, 7
- operation problems, troubleshooting, 40
- optimizing print speed and image band settings, 59
- options, printer, 79
- over-temperature condition, 4
- P**
- page, definition, 107
- pages, copying to another printer, *See* selective transfer

- parallel port
 - bi-directional communications interface, 98
 - using to connect a PC to the printer, 23
 - parallel, definition, 107
 - PDF417, 83
 - picket, definition, 107
 - pitch test label, printing, 64
 - pitch, definition, 108
 - plugging in the printer, 6
 - point size, definition, 108
 - Polling Mode D protocol
 - definition, 108
 - described, 96
 - POSTNET, 82
 - power loss, troubleshooting, 40
 - Power/Data LED, 4
 - preparing the printer for installation, 5
 - preventing data loss, 44
 - print darkness
 - adjusting with darkness adjust control, 49
 - adjusting with PrintSet, 50
 - print quality
 - correcting uneven, 48
 - maintaining, 48
 - optimizing, 48
 - printing test label, 64
 - problems, 42
 - understanding, 48
 - print speed
 - adjusting for use with image bands, 59
 - definition, 108
 - printer
 - cleaning, 31
 - communication problems, 44
 - communications, 27
 - components
 - back view, 3
 - front view, 2
 - connecting to a mainframe, 24
 - connecting to a network, 23
 - connecting to a PC through the parallel port, 23
 - connecting to a PC through the serial port, 23
 - connecting to an AS400, 24
 - connecting to power, 6
 - connecting to your system, 22
 - cover
 - cleaning, 34
 - removing, 7
 - dimensions, 76
 - features, 2
 - inspecting, 30
 - installing, 5
 - maintenance, 30
 - memory, using efficiently, 57
 - opening, 7
 - operation
 - testing, 64
 - troubleshooting, 40, 64
 - options, 79
 - coax interface, 80
 - cutter, 80
 - EasyLAN 10i interface, 79
 - EasyLAN 10i2 adapter accessory, 80
 - EasyLAN Wireless, 80
 - Kanji/Katakana, 81
 - memory expansion, 81
 - self-strip/batch takeup, 80
 - twinax interface, 80
 - plugging in, 6
 - RAM
 - allocation, 57
 - storage limitations, 57
 - understanding, 57
 - serial port, 100
 - specifications, 76 to 78
 - printhead
 - cleaning, 32
 - definition, 108
 - elements, definition, 108
 - troubleshooting, 64
 - specifications, 78
 - printing
 - hardware configuration test label, 14
 - increasing speed, 58
 - method, 78
 - software configuration label, 16
 - speed specifications, 78
 - test label, 28
 - PrintSet
 - using to communicate with the printer, 27
 - using to set the media sensitivity number, 17
 - problems
 - communication, 44
 - print quality, 42
 - printer operation, 40
 - protocols, 94
 - hardware protocol, 96
 - Multi-Drop, 96
 - Polling Mode D, 96
 - Standard, 94
 - user-defined, 97
 - XON/XOFF, 95
- Q, R**
- QR Code, 84
 - quality
 - correcting uneven print, 48
 - optimizing and maintaining print, 48
 - problems, troubleshooting, 42
 - RAM, using efficiently, 57
 - ready, definition, 108
 - Ready/Busy line, definition, 108
 - removing the printer cover, 7
 - requirements
 - electrical, 76
 - host, 98
 - rest point, label, 68

Index

- ribbon specifications, 78
- roll media, loading, 8
- rollers, cleaning, 35
- RS-232, 99
 - definition, 108
 - null modem cable schematics, 101
- RS-422, 99
 - cable schematics, 102
 - definition, 109
- RS-485
 - definition, 109
 - described, 99
- S**
- safety summary, ix
- scan, definition, 109
- scannable, definition, 109
- schedule of maintenance, 30
- selective transfer
 - definition, 109
 - described, 64
- self-strip
 - definition, 109
 - described, 80
- sensitivity, definition, 109
- sensor
 - adjusting the label gap, 54
 - adjusting the label mark, 56
 - cleaning label, 37
- serial interface, 98
 - RS-232, 99
 - RS-422, 99
 - RS-485, 99
- serial port
 - configuration, 25
 - description, 100
 - using to connect a PC to the printer, 23
- serial, definition, 109
- setting the media sensitivity number, 15, 16, 17
- settings, factory default, 78
- skip, definition, 109
- skipping labels, adjusting the printer to stop, 55
- soft font, definition, 109
- software configuration label, printing, 16
- specifications, printer, 76 to 78
- speed, printing, 78
- stacked symbologies, *See* 2D symbologies
- Standard protocol
 - definition, 110
 - described, 94
- symbologies
 - 2D, 82
 - Codabar, 81
 - Code 11, 81
 - Code 128, 81
 - Code 16K, 82
 - Code 2 of 5, 81
 - Code 39, 81
 - Code 49, 82
 - Code 93, 81
 - Data Matrix, 83
 - EAN, 81
 - Interleaved 2 of 5, 81
 - Maxicode, 84
 - MicroPDF417, 83
 - PDF417, 83
 - POSTNET, 82
 - QR Code, 84
 - UPC, 82
- symbology, definition, 110
- T**
- tear bar, cleaning, 35
- terminology, used in this manual, xi
- terms, manual, x
- Test and Service mode
 - changing configuration commands from, 66
 - Data Line Print, 64
 - DIP switch settings, 63
 - entering, 62
 - exiting, 62
 - memory reset, 65
 - printing test labels, 64
 - selective transfer, 64
 - setting Emulation mode, 69
 - using forms adjust, 71
 - X forms adjust, 72
 - Y forms adjust, 72
- test labels
 - printing, 64
 - printing a hardware, 28
- thermal transfer ribbon, loading, 11, 12
- thermal transfer, definition, 110
- third-party software, using to communicate with the printer, 27
- throughput, increasing, 58
- tools for cleaning the printer, 31
- top of form position, fine-tuning, 51
- top of form, definition, 110
- troubleshooting
 - checklist, 40
 - communication problems, 44
 - data loss, 44
 - print quality problems, 42
 - printer operation problems, 40
 - using LEDs, 4
- twinax interface option, 80
- U**
- UDC, definition, *See* graphic, definition
- UDF, definition, *See* soft font, definition
- understanding the front panel, 3
- UPC
 - definition, 110
 - described, 82
- uploading, definition, 27
- user-defined protocol, 97
- using the Feed/Pause button, 5

V, W, X, Y

variable data field, definition, 110

warranty information, ix

X forms adjust

 setting with DIP switches, 72

See also top of form

XON/XOFF

 definition, 110

 protocol, 95

Y forms adjust, setting with DIP switches, 72



Corporate Headquarters
6001 36th Avenue West
Everett, Washington 98203
U.S.A.

tel 425.348.2600

fax 425.355.9551

www.intermec.com

EasyCoder 4420 and 4440 Bar Code Label Printer User's Manual



066392-003